

SOCIETY FOR INDUSTRIAL ARCHEOLOGY

NEWSLETTER

Volume 31

Spring 2002

Number 2

SYRACUSE IA *Review of the 2001 Fall Tour*

Two years ago Dennis Connors, curator at the Onondaga Historical Association (OHA) in Syracuse, NY, wrote an article on Syracuse IA for the SIAN (Spring 2000). When, afterward, I suggested to him that Syracuse would be a splendid city for an SIA Fall Tour, little did I guess that the OHA would promptly step forward and host the 2001 Fall Tour. Not only did OHA staff and volunteers organize an excellent tour in relatively short order, but they did it under the most uncertain circumstances given the events of Sept. 11. Indeed, it was quite heartening that a capacity crowd of more than 100 SIAers gathered in Syracuse Oct. 11-14 and that so many local industries graciously welcomed our group, despite heightened security concerns.

Like so many previous SIA host cities, Syracuse offered us a diverse set of process tours and historic industrial sites for inspection. Arriving in downtown Syracuse by car, I was immediately aware that I had arrived in a venerable northeastern city, which from the evidence of its architecture and signs of urban renewal was working to adjust to the economic realities of the 21st century. The downtown, like so many others, faces stiff competition from outlying suburbs. As I would later find out on an architectural walking tour, Syracuse has made strides to recognize and preserve the downtown's

commercial and industrial heritage, including a splendid block of warehouses and a weighlock on the alignment of the old Erie Canal.

Fittingly, the first event on Thursday afternoon provided an opportunity to learn about Syracuse's historic relationship with the Erie Canal while cruising its successor, the **New York State Barge Canal**. The famous Erie Canal opened in 1825, ushering in a new era in the development of New York and the nation by providing a vital transportation link between the Hudson River and Lake Erie. From the beginning, the canal was closely identified with Syracuse and ran directly through downtown. The canal promoted a boom in Syracuse's first significant industry, salt manufacture. By the early 20th century, the canal had been eclipsed by the railroad, but many New Yorkers still believed in the utility of a cross-state waterway. Voters approved the expenditure of more than \$100 million in 1903 to construct a wider and deeper canal. The New York State Barge Canal, completed in 1918, bypassed downtown Syracuse, but the city maintains a harbor terminal linked with the barge canal via the Seneca River.

The SIA cruise was aboard the **City of Syracuse**, which paradoxically is not a canal boat but a former Chesapeake Bay buy boat that would collect the catches

(continued on page 2)



SIA Fall Tour group poses next to the stone wingwall of the Nine Mile Creek Aqueduct, Camillus Erie Canal Park.



The City of Syracuse, a former Chesapeake Bay buy boat, was the SIA's vessel for a tour of the NY State Barge Canal.

Vance Packard



Larry Mishkar

SIAers board the former New Haven RR Budd Car, built in 1953, at Syracuse's Armory Station.

and take them quickly to market. The first leg of our tour headed west along the main course of the canal from Dutchman's Landing toward Baldwinsville and Lock 24. Adjacent to Lock 24 is the **Mercer Grist Mill**, built in 1827 and added to many times since. The mill still grinds feed but is about to be renovated into an upscale inn. As we emerged from the lock, we were treated to a view of recently restored 100-yr.-old tug, **Urger**, built on Lake Michigan and now used for educational purposes. Also we could see the **Baldwinsville Dam** and **Seneca River Powerplant**, which sells to the Niagara Mohawk grid. At this point, the tour turned around and headed back east toward Onondaga Lake. The trip ended in Syracuse's Inner Harbor with a tour of the New York

State Barge Canal's maintenance facility. Of particular interest was the machine shop and its pre-WW II machine tools.

On Thursday evening, a welcoming reception was held at the **Clinton Exchange**, a Neo-Classical-style building opened in 1928 as a federal office building and post office. The reception was to be followed by a demonstration of the exterior lighting of the exuberantly Art Deco-style **Niagara Mohawk Headquarters Building**, built in 1932, but the display was delayed and many of us didn't see it until the following evening. Still, it was well worth waiting to see the play of colorful lights against the brick, glass, and stainless-steel exterior. The headquarters was to have been the site of Thursday's reception, but security concerns following the Sept. 11 attacks resulted in the reception's relocation to the Clinton Exchange. Despite the sudden change in plans, Niagara Mohawk graciously underwrote the refreshments, and the Pyramid Companies and Michael Lorenz kindly provided us a space in the Clinton Exchange on short notice.

Friday and Saturday were devoted to full days of touring with each day offering an option of Tour A or Tour B. Of course, no better way to begin than to ride a train! Those participants lucky enough to reserve a spot on Friday "A" started at the **Armory Square Station** aboard a former New Haven RR 1953 Budd rail diesel car, operated by the city's **OnTrack** transit system. A few members joined the engineer for a nice view as the car made its way to DeWitt and the first stop, **Jamesville Quarry**. The limestone quarry tour began with a walkabout in an outdoor collection of mining equipment. Included was a Bucyrus-Erie electric shovel and skid-mounted poles that supported the shovel's power cables, a small narrow-gauge steam locomotive and cars for hauling stone, and a portable drill. We learned that quarrying activities at Jamesville began at least as early as the 1850s. The facility greatly expanded when it came under the control of Solvay Process in 1909. Solvay, a major Syracuse manufacturer for nearly a century, required large quantities of limestone for its soda-ash manufacture and ran the quarry until the soda-ash operation closed in 1986. The quarry is currently managed by Hanson Aggregates, with the stone used for highway construction and landscaping. Boarding our bus, we took a driving tour of but a small portion of the 2,238-acre site, taking in the diesel-powered shovels, 70-ton trucks, and the crusher, built in 1928 and among the few pieces of historic equipment still in use. Interestingly,

The *SIA Newsletter* is published quarterly by the Society for Industrial Archeology. It is sent to SIA members, who also receive the Society's journal, *IA*, published biannually. The SIA through its publications, conferences, tours, and projects encourages the study, interpretation, and preservation of historically significant industrial sites, structures, artifacts, and technology. By providing a forum for the discussion and exchange of information, the Society advances an awareness and appreciation of the value of preserving our industrial heritage. Annual membership: individual \$35; couple \$40; full-time student \$20; institutional \$50; contributing \$75; sustaining \$125; corporate \$500. For members outside of North America, add \$10 surface-mailing fee. Send check or money order payable in U.S. funds to the Society for Industrial Archeology to SIA-HQ, Dept. of Social Sciences, Michigan Technological University, 1400 Townsend Drive, Houghton, MI 49931-1295; (906) 487-1889; e-mail: SIA@mtu.edu; Web site: www.sia-web.org.

Mailing date for Vol. 31, 2 (Spring 2002), May 2002. If you have not received an issue, apply to SIA-HQ (address above) for a replacement copy.

The *SIA Newsletter* welcomes material and correspondence from members, especially in the form of copy already digested and written! The usefulness and timeliness of the newsletter depends on you, the reader, as an important source of information and opinion.

TO CONTACT THE EDITOR: Patrick Harshbarger, Editor, SIA Newsletter, 305 Rodman Road, Wilmington, DE 19809; (302) 764-7464; e-mail: phsianews@aol.com.

(continued on page 3)



Larry Mishkar

Jamesville Quarry.

much of the crushed rock comes not from new quarrying but from the 70 million tons of waste rock on the site that was left behind by Solvay because it did not contain a high enough percentage of lime (92%) for the Solvay process. The crusher works only from 2 p.m. to midnight because of lower electric rates, so unfortunately we did not get to see it in operation.

A modern 400,000 sq. ft. building housed the next stop, the **L. & J. G. Stickley** furniture factory in Manlius. Mike Danial, Stickley's resident historian, greeted our group and provided details of the entire process, from rough lumber to finishing. Danial pointed out that Stickley furniture was never "handmade," a frequent misperception, but rather designed to take full advantage of machine processes and finished by hand. Today, the factory employs about 600 production workers. Stickley makes several lines of furniture, much of it inspired by the company's early-20th-century roots in the Arts and Crafts and Colonial Revival movements. Founders Leopold and John George Stickley were two of five Stickley brothers in the furniture business. The best known was Gustav Stickley, who established his famous

Craftsman Furniture factory in 1899. Younger brothers Leopold and John George set up their own business in 1903. The original L. & J. G. Stickley building in Fayetteville (a stop on Saturday Tour B) is no longer in operation, but it still exists and is used for storage and sales. L. & J. G. Stickley's first furniture line, called Handcraft, was very similar to the Craftsman line that Gustav was manufacturing at the time. By the mid 1910s, Arts and Crafts furniture was becoming less popular because of changing tastes. Gustav went bankrupt in 1916, but L. & J. G. Stickley adapted to the times and sought inspiration in the Colonial Revival movement. In the early 1920s, the company inaugurated its Cherry Valley adaptations of American colonial design, which remained popular through the 1950s. The company was on hard times by the late 1960s, but in 1974 Alfred and Aminy Audi bought the company and nursed it back to robust health. They reintroduced mission-style furniture in time to cash in on its recent

revival. The company quickly outgrew the confines of the old factory and moved into the present facility in 1985.

Following lunch in Erie Canal Park in DeWitt, Tour A moved on to see more woodworking, this time at **Marsellus Casket**. Filing off the bus, the group was met by John D. Marsellus, great-grandson and namesake of the company founder. The original John Marsellus established a factory for making broomsticks, medicine chests, shoe-brush handles, and caskets in Syracuse after the Civil War. Eventually, the company grew to specialize in just fine wood caskets. Today, a typical casket utilizes 125 bd. ft. of lumber and requires 45 days to complete. Each casket is a custom design with careful attention paid to individual details. The original 1889 factory in downtown Syracuse is still used for the company offices and to cure the wood in kilns, but we were at the modern facility outside the city where the caskets are made by about 200 workers specializing in various aspects of the production, from roughing and finishing to making linings and attaching hardware.

Interestingly, Marsellus ships many of its caskets to the West Coast by railroad container. How many caskets can a container hold? The answer is 52. Many of the containers pass through the

(continued on page 4)

PROVIDENCE PASSES STRONG MEASURE TO PROTECT ITS INDUSTRIAL HERITAGE

Providence, RI, like many cities of the northeast, has a long history as a manufacturing center. In response to increasing demolition pressures on large-scale, historic, industrial complexes in the city, the mayor has proposed, and the city council has adopted, a comprehensive set of incentives and protections for these resources.

Central to the package is the designation as city landmarks of more than 200 19th- and 20th-century industrial buildings throughout the city. The designation provides for review of proposed demolitions and substantial renovations by the city's historic district commission and makes the buildings eligible for the state's new 30 percent state tax credit for the historic rehabilitation of income-producing buildings.

The action follows a cultural resources survey of industrial

sites undertaken by the Providence Preservation Society in conjunction with the City of Providence and underwritten by the Rhode Island Historical Preservation and Heritage Commission.

Although the National Register of Historic Places includes many so-called thematic designations, which list non-contiguous buildings whose significance derives from a common period, style or association, this apparently is the first time that a municipality has taken such a step. The unanimous adoption of the ordinance by the city council is a testament to the value Providence places on its industrial heritage and a great leap forward toward its protection.

*Catherine A. Horsey
Providence Preservation Society*



Larry Mishkar

L. & J. G. Stickley factory.

CSX Railroad Yard at DeWitt, which was Tour A's last stop of the day. The NY Central opened the DeWitt yards in 1874, part of a freight line routed north of Syracuse to relieve congestion on the old line through downtown. The DeWitt yard lays claim to several firsts in hump-yard operations, including, in 1928, the first major rail yard in North America to have electronically controlled hump switching and retardation, and, in 1979, the first computer-controlled hump yard without retarder tower or retarder operation. The hump yard was closed in 1992 and since then has been extensively redeveloped as an intermodal classification yard. We did stop to see a 1937 reinforced-concrete coaling station (minus hardware) and passed by a modern Bavarian-made snowplow that can spin 360 degrees on its frame to change direction! It cost \$1.5M in 1989.

Process tours were the order of the day on Friday Tour B, with stops to see the manufacture of china, pumps, paperboard boxes, and ball bearings. The first stop was **Syracuse China**, a well-known name in dinnerware. The company traces its roots to the Onondaga Pottery, founded in 1871 in Geddes, NY. In its early years, President James Pass emphasized research and in 1888 he developed America's first truly vitreous commercial clay body, which he later named "Syracuse China." Both beautiful and sturdy, it became particularly prized for its use in public dining rooms, hotels, and railroad dining cars. Our stop was at the company's main plant in Salina, established in 1921, just outside Syracuse, where staff greeted and led our tour. The firm maintains a remarkable archive, including several thousand examples of ware produced during its entire 130-year existence.

Oberdorfer Pumps is another century-old company that welcomed the SIA to Syracuse. Tracing its ancestry to a brass foundry established by John Balch and Moses Oberdorfer in 1875, the company's first pumps were for Lenoir-patent gas engines in the 1890s. Over the years, Oberdorfer went on to supply pumps to a dizzying number of product lines, including Franklin autos, Sherman tanks, Carrier air conditioners, and GE turbojet engines. The pumps have been employed for thousands of purposes, but the largest general category today is marine applications, such as marine-engine fuel pumps and bilge pumps. The company is housed in a modern steel-framed building in DeWitt, having left an older building in Syracuse

in 1993. The SIA group took time to study the display of Oberdorfer pumps in the lobby, from vintage models to modern steel-alloy designs used to handle corrosive liquids. We then toured the shops seeing the storage, machine shop, assembly, and inspection areas. Rough-cast pump bodies are received from outside vendors and finished here. Rotors, shafts, and bushings are machined in-house from bar-stock. Although traditional turret-lathes, milling machines, and multiple-spindle drilling machines are used for low-volume items, the greatest portion of machine work is done on enclosed computer-controlled equipment. Oberdorfer's management was enthusiastic about the SIA's visit and even set up loud speakers at work stations so that employees could give concise accounts of their duties and easily field questions. Many SIA members commented favorably on the knowledgeable enthusiasm of all concerned and the degree of preparation.

From pumps to ball bearings, our next stop was **Kilian Manufacturing**. Like Oberdorfer, Kilian is a supplier to other manufacturers, particularly the automotive industry. It is the sole source of ball bearings used in van and mini-van sliding side-door hangers, and the company is now providing tower bearings used in Macpherson-strut front suspensions. Founded in 1922 by Frederick E. Kilian, the company has been at its present site since 1939.

(continued on page 5)



John Reep

Tour participants discuss pump inspection and testing with employees of Oberdorfer Pumps.

For the final stops on Tour B, the group split in two and alternated between **Jordan Box** and **Mack Brothers Boiler & Sheet Iron Works**. To the delight of tour participants, both of these small family-owned firms continue to use century-old machinery and processes. Jordan Box is located in an 80-year-old building on the southwest side of Syracuse. Established by Charles M. Jordan in 1901, it manufacturers wrapped paperboard boxes, typically used for board games and as department-store gift boxes. Die-cut sheets of cardboard are fed into machines with block-shaped forms that shape the box. Next, heat-setting tape is applied to the corners, knife edges trim the tape flush with the edges, and at the end of the stroke the box drops onto a conveyor belt. This folding process is called "setting-up"; the pieces of tape are called "stays." Since the tape is applied to all corners in one operation, the machine is called a "quad stayer." At the upper end of the conveyor belt, the boxes are placed by hand on glue-coated wrappers, which are folded to the sides in a similar process. Wrappers are generally clay-coated or foiled paper and may be pre-printed or embossed. To produce lids, the setting edges and stay-knives are reset and a slightly larger block-form is employed. Owner Rick Casper was on hand to explain the operation.

Mack Brothers Boiler shop dates to 1883 and has the feeling of a place that has changed little since. The setting is a neighborhood of late-19th-century working-class houses and small industrial buildings, which contribute to the historic flavor of the place. Founders George and James Mack made custom-made steam boilers, unfired pressure vessels, smoke stacks, ducts, and water and air receiver tanks. James G. Hueber, a fourth-generation descendent of the two Mack Brothers continues to operate the shop, engaged primarily in the repair of boilers and associated systems. He was there to greet and guide us through what amounts to a living museum of metal-working tools. The building's profile even harks back to an earlier use: the tall roof projection once allowed for smokestack assembly and testing. Mack Brothers was a great way to end Friday's touring.

As is often the case, Saturday's Tours A and B had an emphasis on museums and historic industrial sites rather than process tours since many factories do not operate on weekends. Both groups inspected sections of the old Erie Canal that have been taken over by parks and museums. Tour A's first stop was **Chittenango Landing Canal Boat Museum**, about 15 miles east of Syracuse. Here a dedicated group of volunteers has uncovered the remains of three dry docks used to construct and repair canal boats from about 1855 to 1917. The site lay abandoned and practically forgotten until they organized with the goal of resurrecting it as a museum in 1985. To date, work has exposed the stone dry docks and uncovered many artifacts associated with canal-boat repair and construction. The foundations of a warehouse and store, carpentry and blacksmith shops, and a saw mill have also been discovered. The warehouse has been reconstructed for use as a museum, gift shop, and classroom. Remains of a sunken canal boat in the adjacent abandoned stretch of the Erie Canal are also interpreted. Most impressive of all is that this has been achieved largely by the labor of local volunteers, who have been careful to seek expert advice from professional canal historians and archeologists. Many of the volunteers were on hand to give us an excel-



John Reap

The Stokes & Smith quad-staying machine (ca. 1930-40) at the Chas. M. Jordan Box Co.

lent tour and orient us to the programs aimed primarily at an audience of grade schoolers.

The **Camillus Erie Canal Park** west of Syracuse was the destination of Tour B. Located along a seven-mile section of the Erie Canal, the park features Sim's Store, a recreated canal-side store. Its most impressive feature is the **Nine Mile Creek Aqueduct**, built in 1839-42 on a revised and enlarged alignment of the canal, and reached via boat, which was particularly pleasant on a bright, warm autumn morning. In the 80 years since the canal's closing, the wooden-trough aqueduct has been partially filled, allowing visitors to walk across the creek. A leisurely stroll along the canal provided time to admire a 1913 Rice & Sargent steam engine, rescued in 1998 from the basement of the L. C. Smith & Brothers typewriter factory in Syracuse and now under restoration in the park.

Leaving the Erie Canal, Tour A traveled a short distance to Lafayette and the original **L. & J. G. Stickley** furniture factory. There, Stickley historian Mike Danial again met our group to guide us through the two-story frame building. Although now devoid of machinery, the building is opened for an occasional scratch-and-dent sale, and it is used to store the company's spectacular in-house collection, which Danial hopes someday to display in a museum setting. Also of interest were the fuming rooms where furniture once was exposed to ammonia gas to achieve a dark finish.

A pleasant lunch was had at Syracuse's **Oakwood Cemetery**, a rustic cemetery designed by landscape architect Howard Daniels in 1859. We wandered the grounds, taking in the monuments and mausoleums built for prominent Syracuse industrialists. Several of the Friends of Oakwood Cemetery were on hand to guide us. The first of two afternoon stops on Tour A was the **Baker Wood Products Lab** at the State University of New York (SUNY) School of Forestry. Faculty gave presentations on the lab and its activities, and appropriately chose as a case study the analysis of red and white pine from the Jay Covered Bridge, a Howe truss built in 1857 and located in the Adirondacks. We also toured their new shop wing and were impressed with the array of scien-

(continued on page 6)

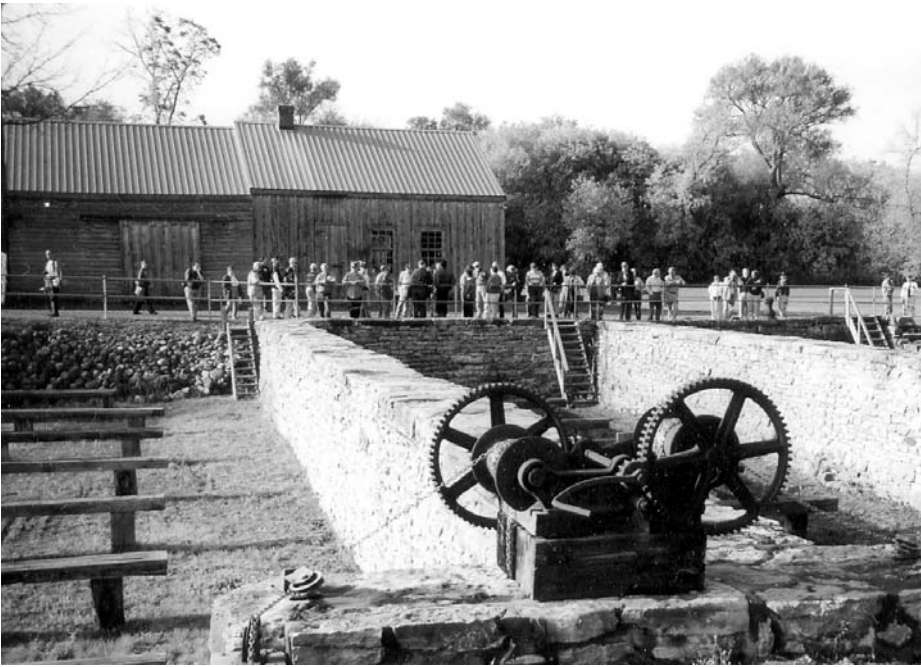

Fall Tour participants examine the dry docks, built in 1855, at Chittenango Landing Canal Boat Museum.

tific equipment in use there. The group also received a quick lesson in dendrochronology, particularly its utility in determining the age of historic buildings.

Tour A's last stop was the **Woodland Reservoir**, where the group was met by employees of the Syracuse Water Department. We appreciated the willingness of Syracuse Water Commissioner Jon Pizepiora to allow the tour given the security concerns following Sept. 11. The reservoir, in a park-like setting, was completed in 1894 as part of the construction of an underground aqueduct that brings freshwater to the city more than 20 miles from Skaneateles Lake. As Syracuse grew, it had faced periodic water shortages, several severe, as well as health problems related to unsanitary drinking water. The 14-acre, 35-ft.-deep reservoir did much to alleviate the problems and has continued in uninterrupted service ever since.

Saturday's Tour B wound its way from the Erie Canal to the village of Liverpool where stops exposed participants to two old area industries. The **Liverpool Willow Museum**, on the grounds of the Liverpool Village Museum and Gleason Mansion, is located in a small shop that once belonged to John and Anna Hurst. The Hursts produced laundry and floral baskets, furniture, and decorative items from the late 1890s to 1929. The handcraft process mainly involved soaking or steaming willow branches to make them pliable and weaving them into the desired shapes. The Hursts were among a large number of German families from the Hesse-Darmstadt region that emigrated to Liverpool and were involved in the basket trade. This was a cottage industry, but its output was impressive; during its peak from 1880 to 1920, Liverpool claimed to have produced three-quarters of all laundry baskets in the U.S., making about 360,000 per year.

Liverpool's **Salt Museum** in Onondaga Lake Park displays a wide range of artifacts from the days when Syracuse and the surrounding region were a center of the salt industry. In fact, Syracuse's nickname is the "Salt City," although very little visual evidence survives of the once-extensive salt works. Around

Onondaga Lake, salt brine naturally flowed from the ground and this is what first attracted salt makers beginning in the late 18th century. The industry boomed in the 19th century, but the techniques of collecting and then using solar evaporation or boiling to crystallize the salt remained basically the same. The wealth that salt generated formed the financial underpinnings for much of Syracuse's later expansion into other industrial endeavors. Salt was last commercially produced in 1926. The Salt Museum is a 1933 re-creation of a salt-boiling block. It includes wooden timbers from a 19th-century salt warehouse and incorporates an original 1850s brick and stone chimney. Also near the museum is the still flowing head of a brine well, now surrounded by commemorative stonework.

Our next stop was Syracuse's **Metropolitan Sewage Treatment Plant** on the site of an old saltworks on Onondaga Lake. The plant was established in 1925 and has had several upgrades since the late 1950s. It handles on average 67 million

gallons of wastewater per day with an 80 million gallon peak capacity. Plant staff gave us a fine tour, offering both a short and long version to accommodate those with tired feet. Tour participants snuggled up close and walked above tanks of fluid, and they saw sludge sterilized and then dried for distribution to farmers for fertilizer.

Tour B's last activity was to board former **New York, Susquehanna & Western RR Motor Car 7** (Budd RDC-1, built in 1950) for the return trip to downtown by rail. This mode of transportation also allowed access to the stone ruins of the **Geddes Pump House**, which is located about 100 yds. through the brush from the former NY Central & Hudson River RR line. The ca. 1860 pump house was constructed by the State of New York to serve the Geddes district of its Onondaga Salt Springs Reservation. The state drilled the brine wells, and the pumps, originally powered by waterwheels (water directed from the Erie Canal) and later by steam engines, forced the brine into wooden reservoir tanks. The Geddes Pump House, one of three that the state built and operated, is the only one still identifiable by above-ground ruins.

Saturday evening the Onondaga Historical Association (OHA) gave the SIA a reception at its museum in downtown Syracuse. The informal and pleasant event provided us a chance to socialize and explore the museum's exhibits on local history, including one recently installed on Syracuse's own Franklin Automobile Co., which operated from 1902 to 1934. The OHA is housed in a five-story Classical Revival-style building erected in 1906 as the offices and exchange of New York Telephone. Following the reception, we walked two blocks to the atrium of City Hall Commons for a buffet dinner. There, two vintage Franklin autos, on loan from Gary Rink and the Northeast Classic Car Museum, classed up the event. Tour coordinator Dennis Connors made a few brief remarks, following which we all joined SIA President Carol Poh Miller in a hearty round of applause to thank Dennis, the OHA, the City of Syracuse, and the many oth-

(continued on page 7)

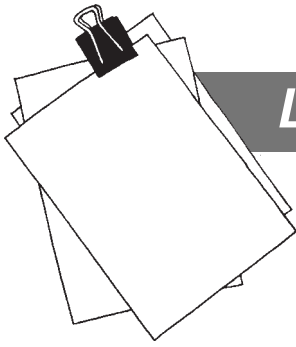

LETTERS TO THE EDITOR

Cornwall—An Open Invitation to SIA Members

To the Editor:

Many thanks for giving such tremendous exposure to Cornwall in the *SIAN* (Winter 2002). This was greatly appreciated and I am sure will result in many more visits to Cornwall from SIA members. I would be pleased if you could publish the telephone number and Web site of the Trevithick Trust in case any other members wish to come here as independent travelers.

Stuart B. Smith, *The Trevithick Trust*
Trevithick Rd., Pool, Redruth, Cornwall TR15 3NB
Tel/Fax 01209 210900; info@trevithicktrust.com
www.trevithicktrust.com

The Trevithick Trust assisted with the organization of the SIA Cornwall Study Tour (Sept. 2001), and Stuart Smith gave an inaugural lecture when the group arrived at St. Ives. The trust manages the King Edward Mine at Troon, the Cornish Mines and Engine at Pool, the Tolgus Tin Stream Works, and the Porthcurno Museum of Submarine Telegraphy. Many thanks to the trust for its support!

Editor

On the Monitor Propulsion Engine:

To the Editor:

Apparently the recovery of an important historic and industrial artifact has not received the publicity it should have.... Here is a brief report:

John Ericsson (1803-1889) trained as a cadet in the Swedish

corps of mechanical engineers. He came to the U.S. in 1839 and designed steam power plants, numerous types of steam engines, and the first screw-propelled man-of-war, the *Princeton*. He is best known for the *Monitor*, the first iron-clad, propeller-driven warship featuring a revolving turret mounting heavy guns. ... It gained fame on March 9, 1862, when it repulsed the *Virginia* in the battle of Hampton Roads. When I was a student in public school during WW I the battle was always referred to as "The *Merrimack* and the *Monitor*." ... Alas, 139 years ago the *Monitor* was lost in a storm and sank in 240 feet of water 16 miles off Cape Hatteras. A project financed as a joint effort by the U.S. Navy, National Oceanic and Atmospheric Administration, and the Mariners' Museum of Newport News has surveyed the wreck and removed the ship's propeller and numerous small artifacts. On July 16, 2001, the massive 30-ton steam propulsion engine was lifted from the deep. It had to be strapped to a 90-ton brace to insure no damage in its removal, lifted by a massive crane on a 300-ft. floating barge, and placed on a smaller barge for the 20-hr. trip to the Mariner's Museum. It was sprayed with fresh water during the trip to prevent salt crystals from forming and expanding the cracks in the metal. Upon arrival at the museum, it was placed in a large tank holding 92,000 gallons of fresh water to prevent any further deterioration from its long immersion in salt water. Complete restoration is a delicate task which will take up to ten years. The project for next year is to recover the gun turret.

William Ellenberger [SIA]
Escondido, CA

The Mariners Museum has an excellent Web site with articles on the *Monitor's* history, including photos and film of the recovery of the propulsion engine. www.mariner.org, click on the "new and exciting" button.

Editor

SYRACUSE (continued from page 6)

ers who made the 2001 Fall Tour a great success.

Sunday morning was our opportunity to explore downtown Syracuse on an architectural walking tour guided by OHA and American Institute of Architects (AIA) staff and volunteers. Syracuse has many fine examples of civic and commercial architecture, and the AIA in cooperation with the OHA has published a tour guide that covers the downtown, as well as surrounding neighborhoods, with accompanying maps and descriptions, copies of which were made available to us. From an IA perspective, the **Erie Canal Weighlock Building**, built in 1849, was the highlight of the walking tour. The Greek Revival-style brick building is the only weighlock building in the Western hemisphere. Akin in idea to modern semi-trailer truck weigh stations, here canal barges would pull off the main Erie Canal and be weighed to determine an appropriate toll. The barges would slip into a cradle at one end of the scale, and then the water would be drained from the lock, to gain a true dead-weight measurement of the barge and its cargo. Unfortunately, most of the scale mechanism no longer exists, but a model was available to show how it worked. The building now houses the **Erie Canal Museum** with numerous displays and a full-size canal boat replica. Staff was on hand to show us through the building, and the snacks provided were a nice touch to re-energize

us on our walking tour.

The 2001 Fall Tour would not have been possible without the support of the OHA and its staff. A special thanks is due to Craig Williams, a central New York native now with the NY State Museum, who generously pitched in to assist Dennis Connors with bus tour guide duties. The OHA produced a fine illustrated guidebook of the sites we visited during the Fall Tour. It also includes a monograph on significant area industries by Syracuse-native and SIA-regular John Reap. John has an impressive knowledge of Syracuse industry in the 20th-century. His write-up includes many companies that we did not visit or that no longer exist in Syracuse; examples of the latter include Air-cooled Motors, Brown-Lipe Gear, Carrier Air Conditioning, Church & Dwight (Arm & Hammer), Continental Can, Crucible Steel, and Easy Washer. John's research includes many hard-to-find details of these companies' operations and eventual decline, making it an important reference for future researchers of Syracuse industry.

Patrick Harshbarger,
with thanks to correspondents Larry Mishkar,
Vance Packard, and John Reap.

Ford Powerhouse Restoration

In Milford, MI, is a small, architecturally striking Art Deco powerhouse built by the Ford Motor Co. in 1939. Officially known as the Pettibone Creek Hydroelectric Station, it was built to supply power to Ford's Milford carburetor factory, one in a series of "village industries" envisioned and built by Henry Ford between 1920 and 1940. The village industries produced parts and supplies for the main production line at the River Rouge Plant in Detroit. Ford often selected sites, like Milford, where earlier millponds and their resulting waterpower still existed. It was an attempt to counter labor unrest in the auto industry and stop the flight of working families from rural southeast Michigan.

Architect Albert Kahn designed the Milford carburetor factory and the two associated hydroelectric stations. The larger of the two stations was demolished in 1997. Kahn was known as an innovative industrial designer and is best remembered for his work on Ford's River Rouge Plant and the General Motors Building.

Water is delivered to the Pettibone Station from the dam by a 3,400-ft., 48-in.-dia. steel flume, providing a 50-ft. hydraulic head of water at the station. Once inside the building, the flume bifurcated to feed two Leffel turbines in the lower level. The turbines remain, but the generators have been removed. The powerhouse tower houses a large steel column that acted as a surge suppressor to absorb the inertia of the moving water when the turbine gates closed. The station was decommissioned around 1953 and acquired by the Village of Milford in 1970.

The Milford Historical Society is working with the Village of Milford to restore and interpret the building, as well as possibly return the turbines to working order. Initial funding has been secured from a combination of private and public sources. The restoration committee is looking for advice from those involved with similar projects. Info: Judith Reiter, Milford Historical Society, 124 East Commerce Rd., Milford, MI 48381; (248) 685-7308; jth401@aol.com

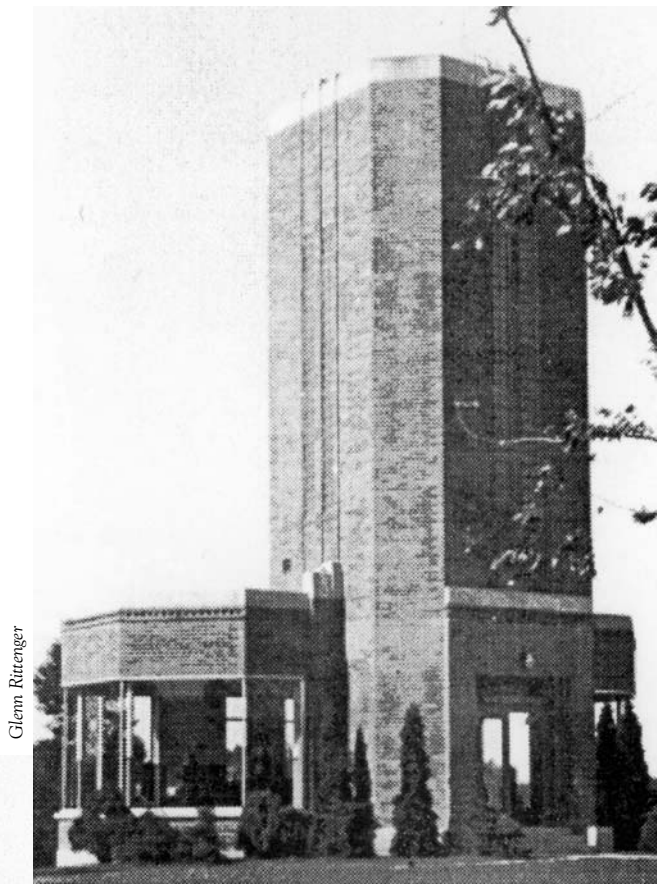

Glenn Rittenger

Pettibone Creek Hydroelectric Station, built in 1939, Albert Kahn, architect.

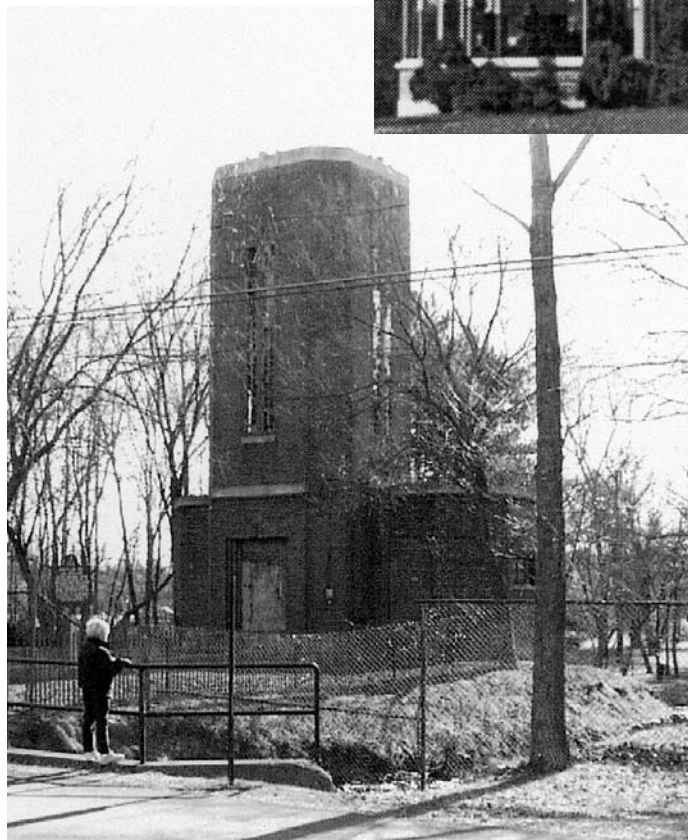

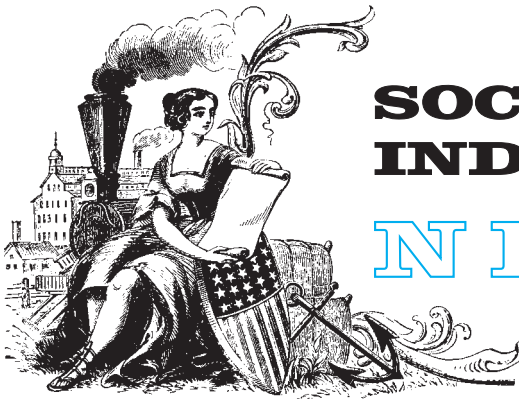

SOCIETY FOR INDUSTRIAL ARCHEOLOGY

NEWSLETTER

PUBLICATIONS OF INTEREST

A Supplement to Vol. 31, No. 2

Spring 2002

COMPILED BY

Mary Habstritt, New York, NY; and Patrick Harshbarger, SIAN editor.

GENERAL INTEREST

- ▶ **Early American Industries Assn. Booklist.** EAIA offers a wide selection of books, many discounted and of IA interest, as one of the benefits of membership. EAIA fosters the appreciation and study of early American industries and antique tools. Info on membership and programs: www.eaiainfo.org. New titles on the most-recent booklist: Garrett Wade Co., *Tools, A Complete Illustrated Encyclopedia*; Gwilyn R. Roberts, *New Lives in the Valley, Slate Quarries and Quarry Villages in North Wales, New York, and Vermont, 1850-1920*; Deborah Defford, ed., *Flesh and Stone, Stoney Creek and the Age of Granite* (granite quarrying in Connecticut); J. Starkie Gardner, *English Ironwork of the XVIIth & XVIIIth Centuries* (first published in 1911, contains analysis of a brilliant phase of English craftsmanship); Nicholas Dean, *Snow Squall, the Last American Clipper Ship* (archeology of an 1851 clipper, discovered in the Falklands); Edward L. Kallop, Jr., *Johnson's Kingdom: The Story of a 19th-Century Industrial Kingdom in the Town of Wayne, Maine* (Holman Johnson operated a series of woolen mills and a shovel-handle factory, 1856-79).
- ▶ Wolfgang Ebert. **ERIH, The European Route of Industrial Heritage.** *TICCIH Bulletin* 14 (Autumn 2001), pp. 4-5. Update on network of European industrial sites working together to develop heritage tourism programs. Ebert was host to the 2001 SIA study tour of the Ruhr. The European industrial heritage program is modeled after the German example [SIAN, Spring 2001].
- ▶ Kingston Heath. **The Patina of Place: The Cultural Weathering of a New England Industrial Landscape.** Univ. of Tenn. Pr. (www.utpress.org), 2002. 288 pp., illus. \$55. Multidisciplinary analysis of workers' housing as an index to social change and cultural identity in New Bedford, MA. Company-owned mill housing and the subsequent transition to a speculative building market resulted in the three-decker rental flat as New Bedford's most common housing form for industrial workers.
- ▶ Richard L. Hills. **Life and Inventions of Richard Roberts, 1789-1864.** Landmark Collector's Library (www.landmarkpublishing.co.uk), 2002. 272 pp., illus., £29.95. Although now little known, Roberts was one of Britain's greatest inventors and the father of production engineering. In 1821, he made the world's first machine for manufacturing industrial gears. Soon after, a power loom. His self-acting spinning mules remained a textile industry standard into the 20th century. He was a partner in Sharp, Roberts & Co., a manufacturer of locomotives, and his punching machine for iron plates was successfully used on the Conway and Britannia tubular bridges. This full-length biography looks at Roberts's life and inventions in the area of machine tools, the gas meter, textiles, road vehicles, locomotives, horology, and shipbuilding.
- ▶ Adrian Jarvis. **The Victorian Engineer.** Shire Publications (UK), 2000. 32 pp., illus., £3.5. Concise and scholarly review of the professionalization of engineering in Great Britain. Rev: *IAR* 23,2 (2001), p. 148.
- ▶ Catherine LaVoie. **The HABS/HAER and the National Register, A Symbiotic Relationship.** *CRM* 25,1 (2002), pp. 14-15. Discussion of the separate missions but complementary roles of the National Park Service's HABS/HAER and National Register programs. In a CRM theme issue devoted to the past, present, and future of the National Register.
- ▶ John R. McGregor. **The Loss of Historic Industrial Structures.** *Material Culture* 33, 2 (2001), pp. 1-28.
- ▶ Marilyn Palmer and Peter Neaverson, eds. **From Industrial Revolution to Consumer Revolution.** Transactions from the TICCIH 2000 Millennium Congress, London [SIAN, Spring 2001]. Avail: Assn. for Industrial Archaeology, c/o Maney Publ., 4th Flr., 44 Brattle St., Cambridge, MA 02138. International perspectives on industrial history from papers presented at 2000 meeting: Barrie Trinder, *Michael Stratton: A Memoir*; Marie Nisser, *A Swedish Response to the Industrial Revolution in the 18th c.*; Jonathan Coad, *A Major Industry Before the Industrial Revolution: Great Britain's Royal Dockyards*; Jean-Francois Belhoste, *Paris, Capital of the Industrial Revolution*; David Rhys Gwyn, 'Ignorant of All Science': *Technology Transfer and Peripheral Culture, the Case of Gwynedd, 1750-1850* (industrialization of N. Wales); Marilyn Palmer and Peter Neaverson, *The Social Archaeology of the Textile Industry*; Michael Mende, *Places of Proto-industry Revisited: Architectural Remains of the 18th- and Early 19th-c. Woolen and Worsted Industries in the Eichsfeld Region of Germany*; Colin Russell, *The Centrality of the 'Chemical Revolution' for Later Industrial Change: A Challenge for Industrial Archaeology*; Garry Champion, 'People, Process, Power and Place': *An Archaeology of Control in East Midlands Outworking, 1820-1900*; Eva Dahlstrom, *Swedish Engineering Industry During the 19th C.: From Diversity to Mass Production*; Jan af Geijerstam, *Swedish Blast Furnaces in India*; Adam Menuge, *Technology and Tradition: The English Heritage Survey of the Northamptonshire Boot and Shoe Industry*; Liv Ramskjaer, *Developing Consumption: The Case of Electric Home Appliances and Plastic Consumer Goods in Norway*; Louise Trotter, *Innovative Materials and Utilitarian Beauty as Incentives to the Consumption of Domestic Appliances in Canada, 1920-1990*.
- ▶ Wayne Parry. **Paterson Looks Back at Great Fire of '02.** *The Star-Ledger* (Feb. 9, 2002). www.nj.com. Worst fire in NJ

history burned 459 buildings to the ground and devastated a great industrial city a century ago. Firefighters, historians, and others mark the anniversary with a series of events.

- **Preserving America's Utopian Dreams** is a theme issue of *CRM: Cultural Resource Management* 24,9 (2001), published by the National Park Service. It includes articles on efforts to preserve several utopian communities that have, or had, industrial components: Rugby, TN; Kennecott, AK; New Harmony, IN; Amana Colonies, IA; Old Salem, NC; Zoar Village, OH; Hancock Shaker Village, MA.
- Ray Riley and Tony Yoward. **Structuration Theory and 19th-Century Corn Milling in Portsmouth.** *IAR* 23,2 (Nov. 2001), pp. 85-92. Structuration theory is explored as a technique of analysis for IA. It looks at industrial sites and artifacts within wider contexts using top-down and bottom-up influences as a way of placing them in political, social, economic contexts. Case study is of a wind-powered mills in Portsmouth, England.
- Colin Rynne. **The Industrial Archaeology of Cork City and Its Environs.** The Stationery Office (Dublin, Ireland), 1999. ISBN 0 7076 6795. 325 pp., illus. £28. Described by a reviewer as "the most important book on Irish industrial heritage to be published in recent years." Includes glossary of Irish technical terms. Beef, pork, herring, butter trades; stone quarrying; malting, distilling, and brewing; linen, woolen, and cotton industries; shipbuilding; roads and bridges; Monard spade mill complex. Rev: *IAR* 23,2 (2001), p. 144.
- Lee Buchsbaum. **Hine's Depiction of Railroaders: Progress and Progressivism on the Pennsy in 1920.** *Railroad Heritage* 4 (2001), pp. 12-15. www.railphoto-art.org. Photographer and journalist Lewis Hine documents life at work on the Pennsylvania RR.
- Alan Clarke. **West Virginia's Coal and Coke Railway.** TLC Publishing (1387 Winding Creek Lane, Lynchburg, VA 24503), 2001. 170 pp., illus. \$24.95. Account of a coal-hauling railroad in central WV, built 1902-05. Taken over by the B&O in 1917. Includes 11 stone bridges along 175 mile route.
- Exhibit Reviews. *T&C* 42,4 (Oct. 2001), pp. 754-766. Scholarly reviews of three new railroad museum exhibits: Charles K. Hyde, *Detroit, Toledo, and Milwaukee Roundhouse, Greenfield Village, Dearborn, MI*; Stefan Zeilinger, *The Works, National Railway Museum, York, England*; Stephen Hoadley, *Steam, The Museum of the Great Western Railway, Swindon, England*.
- Homer K. Folk. **Milton Car Works.** Milton Standard Newspaper (Milton, PA 17847), 2000. 270 pp., illus. \$47. Railroad-car manufacturer began in 1865 and became part of American Car & Foundry. Rev: *RH* (Autumn 2001), p. 129.
- Kenneth French. **Railroads of Hoboken and Jersey City.** Arcadia, 2002. Postcard views and historic photos of the Hudson River terminals of the Erie, NJ Central, and Hudson & Manhattan.
- John P. Hankey. **Pullman Reborn.** *RH* 185 (Autumn 2001), pp. 98-104. Review of ongoing efforts to restore the Pullman shops after tragic fire [*SIAN*, Winter 1998].
- J. David Ingles, ed. **Guide to North American Railroad Hot Spots.** Kalmbach, 2001. 208 pp., photos. \$24.95. 100 of the busiest train-watching sites across the U.S. and Canada, including a color photo and text about each.
- Carla Johnson. **Union Pacific and Omaha Union Station.** South Platte Pr. (Box 163, David City, NE 68632), 2001. 84 pp. \$27.95 ppd. The UP's passenger station and terminal operations from 1860s to 1970s. The Durham Western Heritage Museum is now located in the Union Station, built in 1931. Rev: *NRB* 66,2 (2001), p. 41.
- Randy Kennedy. **Transit Plan Would Connect the Dots Under Lower Manhattan.** *NY Times* (Jan. 23, 2002). In the wake of the Sept. 11 disaster, the Port Authority of NY is making ambitious plans to rebuild the rail transit network. It hopes to untangle seven overlapping lines, the inheritance of decades of independent planning by competing subway and railroad companies operating under the city streets.
- Mary Beth Klatt. **Back on Track: Group Provides Funds to Keep Rail Depots in Public Use.** *Chicago Tribune* (Dec. 16, 2001), Sec. N, pp. 1, 5. Great American Station Foundation provides funds for municipalities seeking to reopen railroad depots.
- Chris J. Lewie. **Two Generations on the Allegheny Portage Railroad.** Burd St. Press (Avalil: C. Lewie, 5377 Edie Dr., Hilliard, OH 43026; www.twogenerations.com), 2001. \$15 ppd. Opened in 1834, the Allegheny Portage RR was a technological marvel that allowed sectional canal boats to be lifted over the mountain ridges between Hollidaysburg and Johnstown, PA. Two generations of the Humphreys family of Cambria Co. worked on the portage railroad.

RAILROADS

- Anthony J. Bianculli. **Trains and Technology: The American Railroad in the Nineteenth Century, Vol. 2, Cars.** Univ. of Del. Pr. (440 Forsgate Dr., Cranbury, NJ 08512), 2002. 254 pp., illus. \$65. Development of passenger cars, freight cars, non-revenue cars, and components of cars including trucks, brakes, and couplers. 2nd vol. in a series devoted to easily understood, jargon-free discussions and explanations of 19th-century railroad technology. First vol. (2001) was locomotives.

CONTRIBUTORS TO THIS ISSUE

Susan Appel, Champaign, IL; James and Diana Bouchard, Pointe Claire, Quebec; Alan Clarke, Montclair, VA; Arlene Collins, Houghton, MI; Dennis Connors, Syracuse, NY; Eric DeLony, Washington, D.C.; James Douet, Terrassa, Spain; Don Durfee, Houghton, MI; William Ellenberger, Escondido, CA; Betsy Fahlman, Tempe, AZ; Bob Frame, St. Paul, MN; David Guise, Georgetown, ME; Mary Habstritt, New York, NY; David Hayes, St. Croix, Virgin Islands; Kingston Heath, Charlotte, NC; Neill Herring, Jesup, GA; Catherine Horsey, Providence, RI; Jack Landesberg, Mequon, WI; Chris Lewie, Hilliard, OH; Paul Lusignan, Washington, DC; Pat Martin, Houghton, MI; Carol Poh Miller, Cleveland, OH; Larry Mishkar, Houghton, MI; Vance Packard, Thorndale, PA; John Reap, Syracuse, NY; Judith Reiter, Milford, MI; Glenn Rittenger, Ann Arbor, MI; Stuart Smith, Redruth, Cornwall, U.K.; Justin Spivey, New York, NY; Charles Varnes, San Dimas, CA; Robert Vogel, Washington, DC.

With Thanks.

- Trevor May. **The Victorian Railway Worker.** Shire Publications (UK), 2000. 32 pp., illus., £3.5. Excellent summary of Britain's railway workforce in the 19th c. Engine drivers, porters, ticket collectors, restaurant staff, construction forces, even makers of artificial limbs for those injured in railway work. Rev: *IAR* 23,2 (2001), p. 148.
- Tom A. Nelson, ed. **50 Years of Railroading in Southern California, 1936-1986** (Plus Updates through 1996). Pacific RR Society, 2001. 204 pp., illus. Originally intended to celebrate the 50th anniversary of the society, this book was expanded to include histories of railroads and rail transit in California's southern counties. Includes 40-p. chronology, line-by-line histories, reviews of local railway museums. Chapter on passenger service by Charles Varnes [SIA].
- David Rollinson. **Railways of the Caribbean.** Macmillan Educational (Macmillan-caribbean.com), 2001. 128 pp., illus., approx. \$25. Also avail. from St. Croix Landmarks Society (www.stcroixlandmarks.com). Well-illustrated guide with island route maps for Bermuda, Bahamas, Cuba, Jamaica, Hispaniola, Puerto Rico, St. Croix, St. Kitts, Antigua, Guadeloupe, Dominica, Martinique, St. Lucia, Barbados, Aruba, Curacao, and mainland routes of Guyana and Belize. Covers the various sugar-cane, fruit, and mineral lines and passenger services, including trolleys. An amazing number of gauges and equipment, also information on what remains of the lines.
- Jack Rudnick and Mike Bezilla. **From Iron Ore to Limestone and Lime To Nothing.** *NRB* 66,2 (2001), pp. 4-33. History and operation of the Bellefonte Central RR, a Pennsylvania short line established in 1880s. Description of shops at Coleville, iron furnaces, limestone quarries and lime plants on its route. All but a short section of line is abandoned today. Photos and maps.
- Joseph P. Schweiterman. **Abandoned Corridors.** *RH* 185 (Autumn 2001), pp. 20-45. History of rail abandonment in the U.S. Considers how the shrinkage of the rail network from 250,000 route miles in 1916 to about 130,000 route miles today has affected small and medium-sized communities.
- Thomas T. Taber III. **Railroad Periodicals Index, 1831-1999.** Published by the author (504 S. Main St., Muncy, PA 17756), 2001. 841 pp. + CD-ROM. \$75. A seminal reference work by a well-respected railroad historian. Subject index of every major North American railroad industry serial. Over 80 titles indexed. Rev: *RH* (Autumn 2001), p. 114.
- John Teichmoeller [SIA]. **Pennsylvania Railroad Steel Open Hopper Cars: A Guide for Enthusiasts.** Highlands Station, Inc. (2600 S. Parker Rd., Ste. 1-211, Aurora, CO 80014), 2000. 160 pp. \$26.95 ppd. Exceptionally detailed account in chronological order of PRR hopper cars from 1900 to 1960, demonstrates evolution of freight-car technology. For the railroad modeler and railroad historian alike. Rev: *NRB* 66,2 (2001), p. 40.
- Gordon J. Thompson, ed. **Niagara Gorge Belt Line: A Pictorial Album.** Niagara Frontier Chapter, NRHS (21 Francis St., Middleport, NY 14105), 2000. 67 pp., illus. \$16.95 ppd. Electric tourist railway operated below Niagara Falls from 1893 to 1935.
- John C. Van Horne, ed. **Traveling the Pennsylvania Railroad: The Photographs of William H. Rau.** Univ. of Penn. Pr. (1-800-445-9880), c. 2001. 272 pp., illus., maps. \$49.95. In the 1890s, Rau, Philadelphia's preeminent commercial photographer, was commissioned to take more than 450 large-format photographs along the routes of the Pennsylvania RR to promote leisure travel to the general public. Remarkably detailed prints display the railroad, as well as the natural and industrial landscapes.
- Joseph Welsh. **Passenger Trains of Yesteryear.** Kalmbach Books (www.kalmbachbooks.com), 2001. 2 vols., \$19.95 each. Photo books focus on passenger service in postwar Chicago. Vol. 1 covers the eastern lines and vol. 2 the western lines.
- Jeff Wilson. **E Units: Electro-Motive's Classic Streamliners.** Kalmbach Books (www.kalmbachbooks.com), 2002. 126 pp., illus. \$21.95. Album of black-and-white photos of streamlined diesel locomotives of mid-1930s to mid-1950s. Succinct Electro-Motive company history includes some shop views.

WATER TRANSPORT

- Jeffrey M. Dorwart and Jean K. Wolf. **The Philadelphia Navy Yard: From the Birth of the U.S. Navy to the Nuclear Age.** Univ. of Penn. Pr., 2001. 271 pp. \$45. Rev: *T&C* 42,4 (Oct. 2001), p. 811.
- Ted Rafuse. **Coal to Canada: A History of the Ontario Car Ferry Company.** Steampower Pub. (54 Walton St., Port Hope, Ontario L1A 1N1), 2000. 90 pp., illus. \$27.95. Railroad car ferry across Lake Ontario between Charlotte, NY, and Cobourg, ON. Operated from 1907 to 1950. Rev: *RH* (Autumn 2001), p. 121.

AUTOMOBILES & HIGHWAYS

- **America's First Concrete Street.** *SCA News* (Winter 2001), p. 7. In 1891, Bellfontaine, OH, claims to have built the first concrete street in the U.S. In 1893, sections of the pavement were displayed at the Chicago World Fair, winning a prize and prompting other cities to pave with concrete. Today, Bellfontaine's streets are marked by several commemorative plaques and a statue of George Bartholomew, the man who advocated the paving material more than 100 years ago.
- Landmark Collector's Library (www.landmarkpublishing.co.uk) offers a series of books on historic roads (pre-automobile era) in Great Britain: David Hey, **Packmen, Carriers & Packhorse Roads**, 2nd ed., 2001. 192 pp., maps, illus. £19.95. Incredible detail on the movement of commodities in N. Derbyshire and S. Yorkshire—spices, malt, iron, lead, etc.; A. E. Dodd and E. M. Dodd, **Peakland Roads & Trackways**, Reprint ed., 2002. 192 pp., photos, maps, £19.95. Classic account of packhorse ways, saltways, drovers' roads, turnpikes; Richland Moore-Colyer, **The Welsh Cattle Drovers**, 2nd ed., 2001. 192 pp., illus, maps, £19.95. Detailed look at trade in the 19th c., with particular detail on the "mechanics" of droving, financing, and general conducting of the trade; Richard Moore-Colyer, **Roads & Trackways of Wales**, 2nd ed., 2001. 192 pp., illus., £19.95. Roman roads, Medieval trackways, drove roads, and turnpikes.
- Norman Painting. **Alldays & Onions: A Brief History.** Landmark Collector's Library (www.landmarkpublishing.co.uk), 2002. 224 pp., illus., £24.95. Birmingham (UK)-based company made a bewildering variety of products from bunsen burners to enormous fans, but was best known for Matchless motorbikes and its cars, tractors, and buses.
- Claudette Stager and Martha Carver. **Winged Wonder: The Airplane Gas Station Revisited.** *SCA News* (Winter 2001), pp. 4-5. Extant Knoxville (TN) gas station from the 1930s

was built to look like an airplane. Wingspan of 42' provided shelter for the pumps. The fuselage was the office and stock room.

POWER GENERATION

- ▶ T. Lindsay Baker, ed. **Windmillers' Gazette**. Quarterly. Avail: Box 507, Rio Vista, TX 76093. www.windmillersgazette.com. \$20/yr. Dedicated to the preservation of America's wind-power history and heritage. Vol. 21,1 (Winter 2002) includes *The Wireless Means Life Itself: The Wind Generator and the Radio on the 1937 Russian North Pole*. Also now avail. are 10-year indexes (1982-1991, 1992-2001). Past *Windmillers' Gazettes* remain in print and avail. for \$5 ppd.
- ▶ Richard L. Hills. **James Watt. Vol. 1: His Time in Scotland, 1736-1774**. Landmark Collector's Library (www.landmarkpublishing.co.uk), 2002. 416 pp., illus., £ 29.95. Hills has worked from original records to shed new light on thus-far obscure areas of Watt's life and personality, attempting to dispel inaccuracies perpetuated by earlier biographers of the man best known for his work on the steam engine. This volume includes information on Watt's family background, training as a mathematical-instrument maker, involvement with Scottish salt and pottery industries, work as a civil engineer, and early investigations of steam power. Vol. 2 (due out 2003) will cover his time in England (1774-1819) including the partnership with Matthew Boulton and the development of the rotative steam engine.
- ▶ Maureen Milford. **Pennsylvania Power Plant to Get New Life as Offices**. *NY Times* (Dec. 16, 2001), Real Estate Sec., p. 6. Chester, PA, power plant, built in 1918, housed in a magnificent Neo-Classical building, has been vacant for 20 years.
- ▶ John Walter. **Saving the Survivor: The British Éolienne Bollée**. *IA News* 119 (Winter 2001), pp. 7-8. An innovative 19th-c. wind engine, originating in Le Mans, that generates power from a simple reaction turbine. More than 300 turbines of this type were installed in central France. Additional info: www.bollee.fsnet.co.uk.

WATER CONTROL & RECLAMATION

- ▶ Michael H. Gould. **The Development of All-Metal Water Towers**. *IAR* 23,2 (Nov. 2001), pp. 113-123. British and Irish metal water towers from the mid-19th to mid-20th c.
- ▶ Andrew C. Revkin. **21st-Century Plumbing for New York City's Leaky Old Water Tunnel**. *NY Times* (Mar. 12, 2002), Science Section. Delaware Aqueduct, opened in 1945 to supply NYC from the Delaware R. watershed in the Catskill Mts., is leaking 25 to 34 million gallons per day. Problem: the leaks are 600 ft. underground and from uncharted breaks in the tunnel's concrete and steel lining. Techniques to locate and fix the leaks include using an unmanned submarine to ply the 45 miles of tunnel, which has not been drained in nearly 50 years.

BUILDINGS & STRUCTURES

- ▶ Robert Lewis. **Redesigning the Workplace: The North American Factory in the Interwar Period**. *T&C* 42,4 (Oct. 2001), pp. 665-684. Manufacturers selectively adapted elements of rational factory design and diverse production strategies when remodeling, replacing, or adding on to existing shops to create work spaces tailored to their circumstances.

- ▶ Michael O'Malley. **Pushing On, Nun Finds Historic Revolving Doors**. *Plain Dealer* (Dec. 18, 2001). pp. A-1,14. Ursuline nun, who works in the Cleveland Public Library, rediscovers inventor of the revolving door, Theophilus Van Kannel, who received a patent in 1888. Van Kannel doors were manufactured in Philadelphia and sold from a retail store in Cleveland. Thousands are still in use today.

MINES & MINING

- ▶ John Cornwell. **Collieries of South Wales**. Landmark Collector's Library (www.landmarkpublishing.co.uk), 2002. 256 pp., illus., £22.50. Nearly 300 photographs of mines and miners at 39 pits, chiefly taken since 1947. Colliery headframes and buildings, aerial photos, coal faces, views in drainage levels, shafts, etc. Also, **Collieries of Somerset & Bristol**, 2001. 112 pp., illus., £14.95. Over 80 photos taken in the 1960s and 1970s, includes the Kilmersdon self-acting incline.
- ▶ William B. Thesing. **Caverns of Night: Coal Mines in Art, Literature, and Film**. Univ. of SC Pr., 2000. 282 pp. \$39.95. Essays show just how extensively the coal industry has been portrayed in painting, poetry, song, film, and fiction. Rev: *T&C* 42,4 (Oct. 2001), p. 789.

TEXTILES

- ▶ Robert Pavey. **Leader Seeks to Promote Past**. *Augusta (GA) Chronicle* (Jan. 29, 2002), p. 1B. Augusta Canal Authority undertakes heritage area project along power canal. Includes visitors center in Enterprise Mill, trails, rehabilitating mills for apartments and offices.
- ▶ Ron Wertheimer. **Mills' Tale, With Fact Husked of Fiction**. *NY Times* (Jan. 2, 2002) Arts Sec. Not terribly flattering review of Mill Times, PBS's adaptation of David Macaulay's book, *Mill*. "The hour blends elements of standard documentary with animated storytelling to offer an easy-to-take introduction to New England's textile mills." ■

ABBREVIATIONS:

CRM	= Cultural Resource Management, published by the U.S. National Park Service
IA News	= Industrial Archaeology News, published by the Assn. for Industrial Archaeology (UK)
IAR	= Industrial Archaeology Review published by the Assn. for Industrial Archaeology (UK)
I&T	= American Heritage of Invention & Technology
NRB	= National Railway Bulletin, published by the National Railway Historical Society
RH	= Railroad History, Journal of the Railway & Locomotive Historical Society
SCA News	= Society for Commercial Archeology News
T&C	= Technology & Culture: Quarterly of the Society for the History of Technology
TICCIH Bulletin	= The International Committee for the Conservation of the Industrial Heritage Bulletin.

Publications of Interest is compiled from books and articles brought to our attention by you, the reader. SIA members are encouraged to send citations of new and recent books and articles, especially those in their own areas of interest and those obscure titles that may not be known to other SIA members. *Publications of Interest* c/o SIA Newsletter, 305 Rodman Road, Wilmington, DE 19809; phsianews@aol.com.

IA in Art

Arnold Rönnebeck

Arnold Rönnebeck (1885-1947) was part of an international company of adventurous artists who immersed themselves in the Parisian avant-garde during the teens. With the commencement of WW I, he returned to his native Germany to enter military service. After the Armistice in 1918, he established himself as a successful portrait sculptor in Berlin. But a series of personal discouragements made him decide to leave Europe and settle in America. He arrived in New York in 1923 and soon became part of the adventurous circle centered around photographer and gallery impresario Alfred Stieglitz. Rönnebeck had already formed friendships with several American modernist artists before arriving in America, including Precisionist painter Charles Demuth, who was beginning to explore industrial themes.

Rönnebeck was impressed with the energy of New York, and this city of dynamic forces fascinated him, as it did other European visitors. He roamed the city with a camera, and his snapshots inspired a series of lithographs. One, *Brooklyn Bridge*, pictures that 19th-century engineering marvel that became an icon for modernism in the 20th. Many artists and writers found inspiration in the powerful Gothic double arches of the towers that supported the taut suspension cables of the structure which linked Brooklyn with Manhattan. The closely spaced docks and warehouses on shore and the boats in the busy harbor suggest the extensive commercial activity taking place on the waters between the two boroughs. One vessel bears the initials of the Coast Guard ("CG"). Above, the sky is a skeletal web of intersecting Futurist lines of force that dramatically convey the vigorous urban rhythms that so excited those who converged on this gateway metropolis. Beyond these elements are visible the rising canyons of skyscrapers, technological feats of modern construction and design that were symbols of American wealth and business. New York was a modern city like no other and artists responded to the bustling energy of its inhabitants (who typically are not seen) and the alluring spectacle of the structures in which they worked. The dynamic geometry of the modern city appealed to artists steeped in abstraction. A fragment of the bridge is also visible in a later lithograph, *Manhattan* (1928), a night scene picturing the city's glittering skyline. Another New York print, *Wall Street* (1926), was a powerful image of the city's financial district.

Rönnebeck married painter Louise Emerson in 1926, and left New York that same year. On their honeymoon trip, the couple stopped in Omaha, where Arnold had received several commissions. He was impressed with the city's landmark grain elevators. He moved west to assume the directorship of the Denver Art Museum. Although he resigned this position in 1930, he remained in Colorado for the remainder of his career.

The Rönnebecks had a summer cabin in the Rocky Mountains near Central City, a former gold mining camp about fifty miles northwest of Denver. Both recorded the structures they saw there, he in prints and she on canvas (this was an unusual subject for a woman artist). Gold had first been discovered in Gilpin County in 1859, but by the time the Rönnebecks arrived, the town's boom years were long past. The Depression era was ironically a time of renewal for Central City, for the Opera House, built in 1878, was restored in 1932. It opened with a performance by Lilian Gish. This town and those nearby exerted a

(continued on page 17)

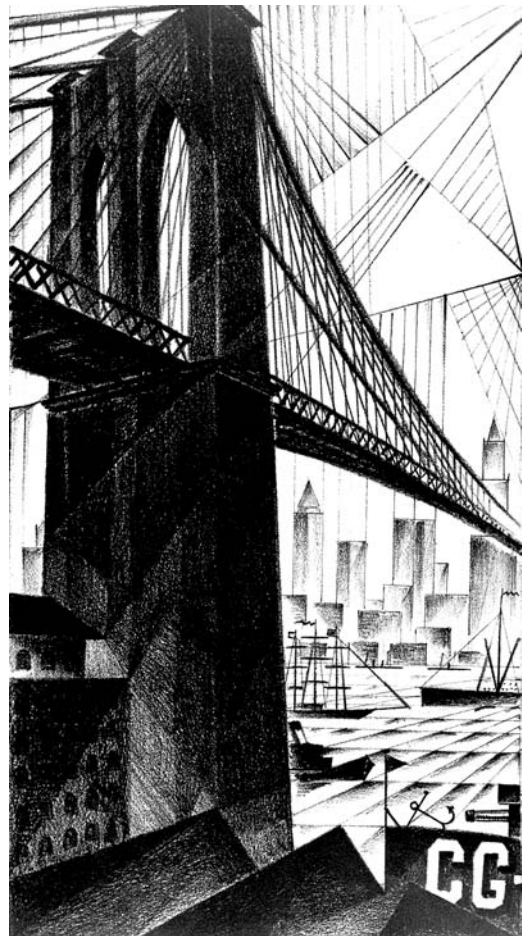

Arnold Rönnebeck, *Brooklyn Bridge*, 1925.
Lithograph, 12 5/8" X 6 5/8" (image), private collection.



Arnold Rönnebeck, *Central City, Colorado*, 1933.
Lithograph, 15 X 10 3/8" (image), private collection.

Elusive American Truss Bridges

David Guise [SIA] is researching the evolution of the 19th-century American truss bridge for an upcoming book. In this, the fifth installment in a series (see previous issues for the Greiner, Kellogg, Stearns, and Thacher trusses), he shares his research to date on the Horton bowstring truss. The series is intended to serve as a catalyst to elicit additional information, especially the location of historic photos, plans, descriptions, and surviving examples.

Info: David Guise, Box 132, Georgetown, ME 04548; phone/fax (207) 373-2651.

Horton's Bowstring Truss

In 1897, Charles Horton patented a bowstring truss configuration that contained several innovative features. The most notable, and visual, innovation was that the truss web panels contained two separate sets of tensile members. One set consisted of a fairly standard pair of crossed diagonals. The second set formed an inverted V with the apex attached along the upper chord midway between the posts that framed the crossed diagonals (Fig. 1). Horton's patent also called for a unique and, unfortunately, complicated connection between the web members and the arched chord. In practice, Horton's patented solution created as many engineering problems as it solved. Some of his solutions appear to be redundant, and others seem entirely self-induced. As far as is known, only a handful of examples were built in Wisconsin.

The mystery of why Horton believed his solution was an improvement on the available competition is compounded by the late date of his proposal. By the late 19th century, pony bowstring trusses were a common, almost ubiquitous, truss form. A variety

of successful configurations, far simpler to build, had been developed since Squire Whipple patented his bowstring truss in 1841. The majority of the successful bowstring variations, developed during the intervening half-century, proposed improvements in the fabrication of the arch-chord and ways to simplify the joints between the web members and the chords. Most bowstring trusses, including Whipple's elegant original (Fig. 2), relied on simple crossed-diagonal web panels, a solution also commonly used in parallel chord trusses.

Horton's patent called for the strong axis of the I-beam forming the arch-chord to be placed in the horizontal plane. Doing so increased lateral stability. Lateral stability is a constant issue in pony-truss designs, as their low height obviates the possibility of providing overhead lateral bracing between the top chords. The most common method of providing lateral stability for the top chords of pony trusses is by bracing them with diagonals called outriggers. The extant Horton bowstring truss bridges all have outriggers as called for on the patent drawings (Fig. 3). Their use would seem to negate the need for the additional stabilizing provided by the placement of the I-beam.

Furthermore, the horizontal placement of the stronger axis resulted in less material being available to resist vertical buckling. A weak arch-chord tends to undulate when a heavy load moves across a bridge. When an arch is loaded at a particular point it tends to be deflected downward due to the load suspended from it and, since the total length of the arch is a constant, this creates a tendency for the arch to undulate or buckle upward at a compensating point. Apparently, to offset the diminished vertical stiffness of his top chord, Horton added the inverted V's to strengthen the chord halfway between the main panel points. The inverted V's act as downward anchors to control any upward tendency. The cost of the material and labor required to furnish the extra rods and anchors needed to make and secure the V's would seem to far outweigh the additional cost of increasing the vertical dimension of the arched top chord to make it stiff enough to control any tendency to undulate or buckle.

The thrust of Horton's explanation of his patent design focused on his unique joinery method. He was greatly concerned that the prevailing methods used to connect one truss member to another (pins, rivets, and bolts) required holes that weakened the pierced

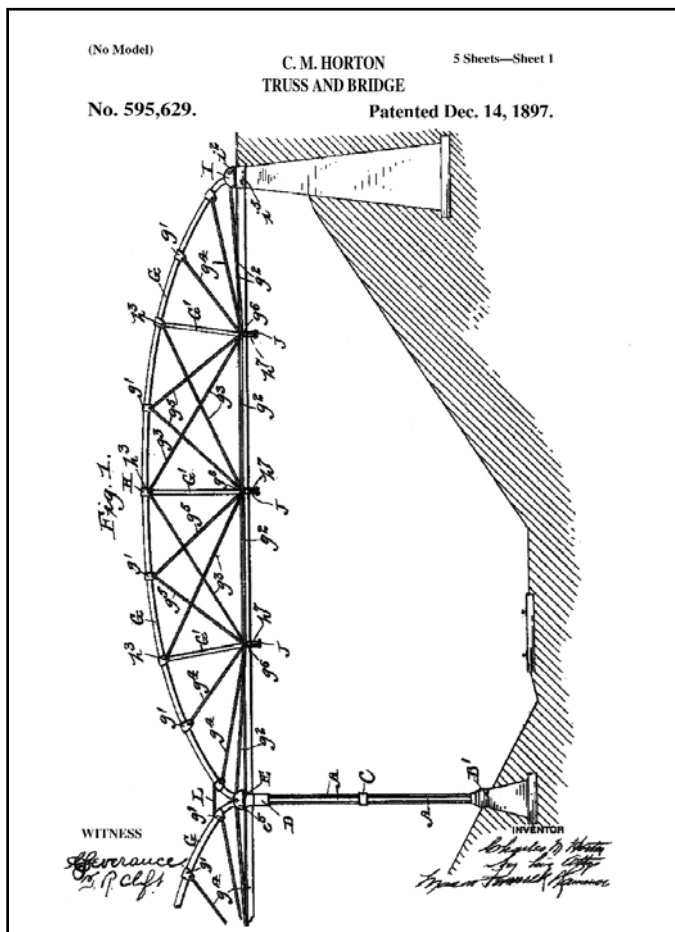

Figure 1: Horton's 1897 patent.

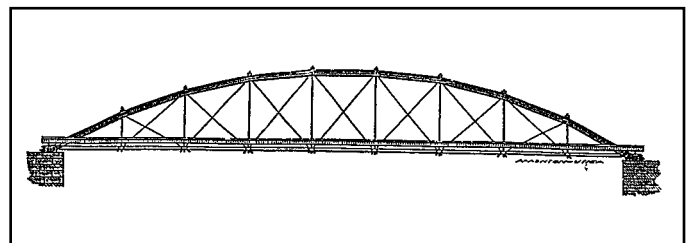

Figure 2: Whipple bowstring truss.

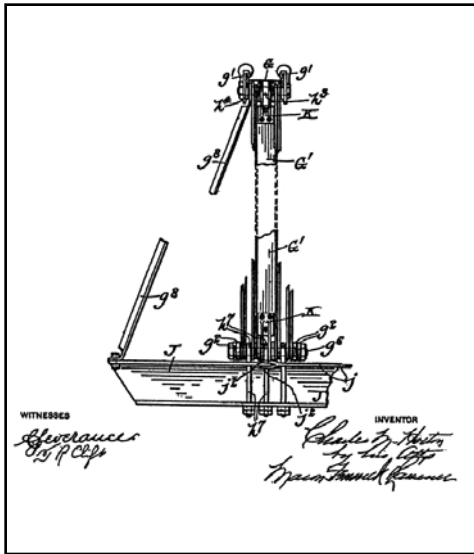

Figure 3: Detail from Horton's 1897 patent, showing outriggers and connection details.

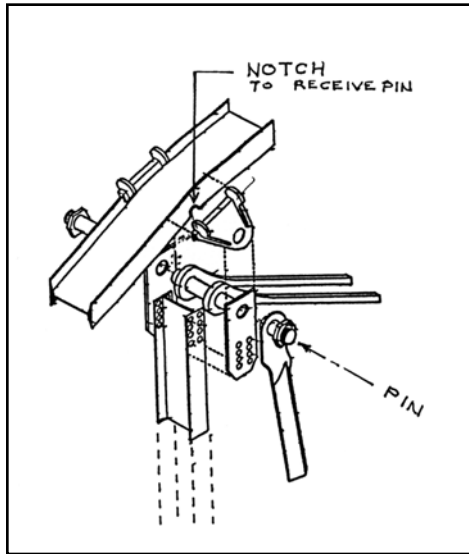

Figure 4: Horton's clamp connection. Source: HAER WI-22.

members. In response to this issue Horton devised a variety of clamps and clips for securing the web members to the arch-chord.

Horton's concept of using a clamp to avoid drilling or cutting his truss parts has an appealing logic. To physically accomplish this, however, he had to successfully resolve several issues. The clamp had to be capable of handling the stresses placed on it as well as remaining tight under traffic-induced vibrations. Additionally, it had to be cost-efficient—a difficult challenge due to the need to make special castings. The combined costs of time and materials had to be less than the expense of sizing members to compensate for the material lost due to the hole made for the bolt or rivet. A gap developed between Horton's idea and the reality of his execution. Inconsistent with his stated concerns, the patent drawing indicates that a notch must be cut into the arch-chord to receive the clamp used to connect the web members to the chord (Fig. 4). The connections were built in accordance with the patent drawing. The removal of material in the notch contradicts Horton's stated premise of conserving material. Horton was thus left with the worst of both issues: the loss of material (thus weakening his chord) and the cost of the clamp. It may even be that the reason Horton placed his I-beam chord with

its web horizontally and flanges vertically was to facilitate making his clamp connection rather than to provide lateral stability. We can only speculate.

How his truss form, with its specially shaped parts and double set of web tensile members, could become competitive defies speculation. Yet a number of Horton's trusses were built in the early 1900s, including six in an area slightly north of LaCrosse, WI (Fig. 5). Five of these are still in use as foot-bridges in the VanLoon Wildlife Area. The only apparent cost saving over alternative truss shapes may have been in obviating the payment of patent fees to a rival, since the bridge building firm Horton had formerly headed was the contractor for the bridges.

We can only speculate on why Horton chose his particular combination of innovations. Placement of the strong axis of his chord in the horizontal plane, while simultaneously using outriggers to support it, seems redundant. The consequence of no longer having the strong axis in a vertical plane led to the insertion the mid-panel-point tie-down V's to compensate for the decreased vertical stiffness, throwing additional confusion on the ultimate reason Horton placed his axis as he did. The use of clamps that required removal of chord material to secure them appears to have an inherent conflict of its own.

Horton's bridge is an intriguing conundrum. We know *what* it is, but we don't know *why* it is. He left us a few clues as to what inspired it. He left no convincing reasons why anyone would want to use his idea in lieu of the available competing truss forms. (Apparently no one did.) No information has come to light indicating whether Horton possessed the knowledge to fully analyze the stresses in the various members of his design. We have the evidence of his patent and the surviving bridges, but so far no clear motive or insight to his reasoning has come to light. Horton's truss is a captivating, non-conforming, and isolated piece of American engineering—picturesque proposal that, although functional, proved not to be efficient enough to meet the competition. ■



Figure 5: One of five extant Horton bowstring trusses in the VanLoon Wildlife Area north of Lacrosse, WI. Source: HAER WI-22B-2.

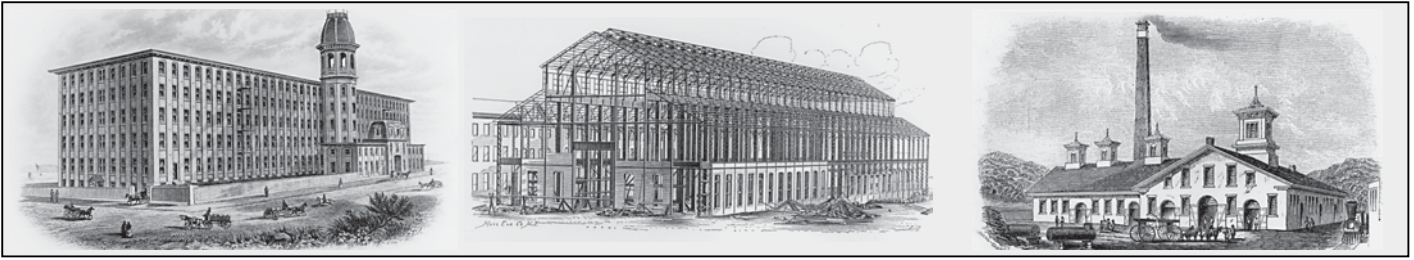

IA IN THE NATIONAL REGISTER OF HISTORIC PLACES

COMPILED BY

Paul Lusignan, National Register of Historic Places, Washington, D.C.

National Register Entries: May 1–Oct. 6, 2001:

OHIO. Jeffrey Manufacturing Co. Office Building, Columbus. The neo-classical style office building (1924) and attached Research Development and Testing building (1946) associated with preminent 20th-c. coal-mining equipment manufacturer.

OREGON. River Mill Hydroelectric Project, Estacada vicinity. Hydroelectric power generating facility (1911-13), includes powerhouse, dam, spillway dam, gatehouse, and fish ladder. The reinforced-concrete, Ambursen-type powerhouse dam is 173-ft. in length with an 86-ft. high downstream face and nine-ft. diameter riveted steel penstocks. The three-story powerhouse was designed for five generators having a peak capacity of 23,000 kW. Units 1, 2, and 3 are original. Unit 4 was added in 1927 and Unit 5 in 1952. The gatehouse contains five large steel rack-and-pinion head-gate assemblies below an open truss roof. Built by Portland Railway Light & Power along the Clackamas River, the hydroelectric plant now is operated by Portland General Electric as part of a system of four separate hydro units: Faraday (1907-10); River Mill (1911); Oak Grove (1924-31); and North Fork (1958) serving the broad Clackamas and Willamette river valleys of north-west Oregon.



River Mill hydroelectric plant and dam, Estacada, OR.

PENNSYLVANIA. Pennsylvania Match Co., Bellefonte. A complex of 18 interconnected buildings built between 1899 and 1947 along Spring Creek and the abandoned Phoenix (flour) Mill race in north-central Pennsylvania. The vernacular brick buildings range from one to three stories and include production facilities, warehouses, material storage areas, and power plant. Established in 1899 by four local businessmen, it was one of the largest wood match factories in the U.S. and represents a rare extant facility associated with Bellefonte's once-extensive lumber industry. Also operated under the names Federal Match and Universal Match, the complex employed 400 at its peak during WWII, but ceased operations soon thereafter due to the greater demand for alternatives, such as book matches and cigarette lighters, and the increased cost of raw materials. No extant machinery.

SOUTH DAKOTA. Chamberlain Bridge, Chamberlain. Large, multispan highway bridge spanning the Lake Francis Case reservoir (Missouri River). Comprised of ten Pennsylvania through-truss spans, the 1953 bridge was the combination of two earlier 1925 Missouri River crossings that were relocated upon the creation of the reservoir. The 1925 bridges were products of the state's first concerted effort to provide a dependable highway crossing of the Missouri. The bridge trusses, ranging in length from 256 ft. to 336 ft., are set in parallel pairs of five spans each with simple deck-girder approach spans. The 1953 reconfiguration of the bridge was an innovative response to the technical problems of highway bridge design.

TENNESSEE. Hardwick Woolen Mills, Cleveland. Textile mill complex including block-long brick mill (1905, 1920, 1955), warehouse (1925), storage buildings (1925), and 180-ft. tall smokestack. Utilitarian design with heavy-timber mill construction, wood columns and monitor roofs. Significant regional wool and men's clothing manufacturer from 1905 to 1950s.

WEST VIRGINIA. Beaver Mill, Craigsville vicinity. Two-story, timber-frame mill (ca.

(continued on page 17)



Pennsylvania Match Co., Bellefonte, PA.

1852) on Beaver Creek in rural Nicholas County. Built by local businessman Kyle Bright, the 25-ft. by 30-ft. mill is the last extant 19th-c. water-powered mill in the county. The original water turbine in the basement has been removed, but much of the historic 19th-c. milling equipment is intact and well-preserved, including French buhr stones, wood and iron shafts and belt pulleys, and bolting and separator equipment.

Cooper's Mill, Jumping Branch vicinity. Small (18 ft. by 16 ft.) vernacular gristmill of log construction was built ca. 1869 and reconstructed in 1930 by Thomas Moody Cooper. The 14-ft. diameter, steel overshot waterwheel (Fitz Water Wheel Co., Hanover, PA) and equipment operated until 1950 and are in place. Traces of the dam and race on the Little Bluestone River are still visible, as is an adjacent ca. 1900 blacksmith shop and forge.

WISCONSIN. Kohler Co. Factory Complex, Kohler. The 89-acre industrial complex, located within the planned company town of Kohler, outside Sheboygan, is home to the internationally known plumbing fixture manufacturer. Built in a park-like setting beginning in 1901, the massive cream brick buildings range from three to five stories, and reflect continuous use and evolution. The main buildings include the Old Main Office Building (1908), Main Office (1925), Enamel Shop (1901-1925), Foundry, Engine Plant, Brass Building, and numerous fabrication and support buildings.

Lawson Airplane Co., S. Milwaukee. Modest utilitarian complex of cream brick industrial buildings (1916, 1928) where the Lawson Airplane Co., between 1919 and 1920, designed and constructed the prototype "Midnight Liner," the second airplane built for commercial passenger use in the U.S. and the first designed as a sleeper. Under the direction of Alfred W. Lawson, publisher of *Fly*, the *National Aeronautic Magazine* (1908), and *Aircraft* (1910-), its head engineers Vincent Buranelli and Lee Wallace used the former industrial facility of the Pan-American Rubber Co. as the design and fabrication shop for what they hoped would become a

100-plane commercial operation. The 24-passenger L-4 "Midnight Liner" was actually the firm's second "airliner" design, but a combination of poor financing and a disastrous test flight doomed the young firm before operations could begin. Recognized by aviation authorities for visionary designs that foreshadowed the later development of multi-engine specialized air transports, the company's efforts were nonetheless disappointing to both its impetuous, entrepreneurial leader and his financial backers.

The National Register of Historic Places is the nation's official list of cultural resources worthy of preservation. Authorized under the National Historic Preservation Act of 1966, the Register is part of a national program to coordinate and support public and private efforts to identify, evaluate, and protect our historic and archeological resources. Properties listed in the Register include districts, sites, buildings, structures, and objects that are significant in American history, architecture, archeology, engineering, and culture. The Register is administered by the National Park Service, which is a bureau of the U.S. Department of the Interior. For more information on the Register, or to obtain copies of particular nominations, contact the Register archives at nr_reference@nps.gov, or by telephone at 202_343_9536, or visit the Web site at: <http://www.cr.nps.gov/nr/>. ■

IA in Art (continued from page 13)

strong visual impact on the artist, and between 1932 and 1933, he executed a series of prints, including *Gem Mining Company*, *Silver Mine*, *Russell Gulch*, *Memories of Gold Rush Days*, *Colorado Gold Dredge*, and *Mine Near the Continental Divide*. Rönnebeck's expressive style captured accurately the barren landscape dotted with abandoned mines.

His lithograph *Central City*, executed the year he became an American citizen, records the buildings cobbled along a steep hill common in such towns. A rickety winding staircase permits access from one part of the town to another. The Precisionist style he had favored in New York was also well suited to picturing the angled Cubist structure of the rugged landscape and the spare beauties of these functional edifices. The stark contrasts of his black and white medium suggest the economic uneasiness of those living in such places during the Depression. Mining is an enterprise indelibly associated with the West and his prints of *Central City* picture a scene as typical of this region as the Brooklyn Bridge was of New York.

Betsy Fahlman

Readers are encouraged to suggest essay ideas for the IA in Art column, or submit their own, to Betsy Fahlman, Professor of Art History, School of Art, Box 871505, Arizona St. Univ., Tempe, AZ 85287; fahlman@asu.edu. ■

NOTES & QUERIES

Asland Cement Works. Historical information is sought on the American engineers and companies that helped set up the first Portland cement works using horizontal rotating kilns in Spain in the late 1890s. The kilns came from Allis Chalmers, and the dozen waterwheels to power them from Pelton Water Wheel. The factory was built high in the Pyrenees, a location chosen for a suitable limestone deposit, but in the back end of beyond. No road reached it and to move the kilns the promoters also imported a steam train from Best Manufacturing of San Leonard, CA. Three engineers came from Allis Chalmers in Milwaukee: Messrs. Ewing, Jenning, and Peek; and five came from Pelton: Messrs. McGuire, Andrews, Jones, Stokel, and Tucker. It seems they stayed a number of years but all returned eventually to the states. The factory, abandoned since the 1960s, will open as a new museum this year, and those involved with the interpretation would like to recover the story of the men who transferred the technology from the U.S. to Spain. The factory, a spectacular design which steps down the mountainside so that the process worked under gravity, is attributed to architect Raphael Guastavino, a Catalan who went the opposite direction to New York in the 1880s and built a large business constructing thin-shell vaults. Info: James Douet, douet@eres-mas.net.

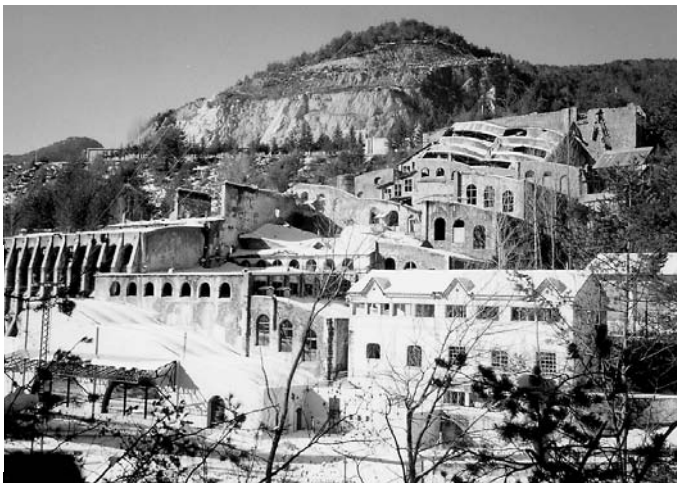

Asland Cement Works, Clot del Moro, Spain.

The Historic American Engineering Record (HAER) and CALTRANS, the California Dept. of Transportation, Dist. 7, Los Angeles, received a California Preservation Foundation Preservation Design Award for their **Arroyo Seco Parkway** documentation project at an awards ceremony Feb. 23, at the Getty Center in Los Angeles. A HAER team of architects, landscape architects, historian, and photographer documented the parkway in 1999. Constructed in three stages between 1938 and 1953, the 8.2-mile parkway (Pasadena Freeway) was the first divided-lane, high-speed, limited-access road in the urban western U.S., and the first stretch of road that would become part of the Los Angeles freeway system. The HAER documentation was cited for the assistance it will provide CALTRANS in developing design guidelines and standards in keeping with the historic character of the parkway as it is upgraded to meet modern highway standards. The six-lane roadway's original design included over 30 bridges, four tunnels, two-toned paving, wooden guiderails, and landscaping with native plants.

Short-term grants-in-aid support visits to the **Hagley Museum and Library**, Wilmington, DE, for scholarly research in the imprint, manuscript, pictorial, and artifact collections. They are designed to assist researchers with travel and living expenses while using the research collections. Scholars receive a stipend, make use of the research holdings, and participate in the programs of the Center for the History of Business, Technology, and Society. A wide range of American and international topics can be explored. Hagley has one of the nation's largest collections of materials related to business, industry, and technology. More information on the collections can be obtained through the on-line catalog at <http://www.hagley.org>. Low-cost housing may be available on the museum grounds. Stipends are for a minimum of two weeks, maximum of two months at no more than \$1,400 per month. Deadlines for 2002: June 28 and Oct. 31. Info: Carol Ressler Lockman, HML, Box 3630, Wilmington, DE 19807: crl@udel.edu; (302) 658-2400. ■

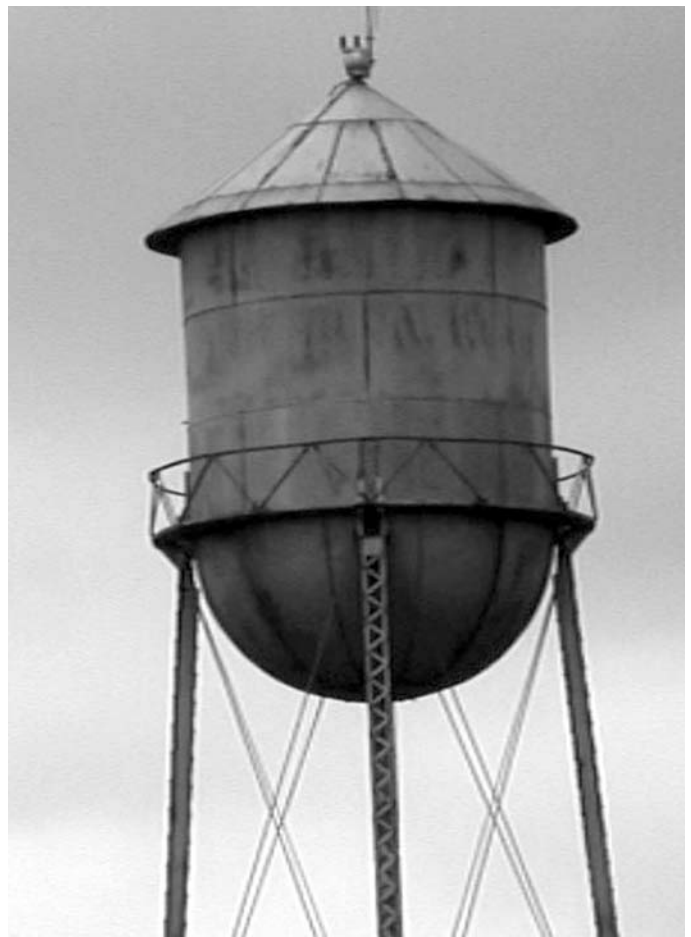

This steel water tower, located in Austin, TX, has recently been retired. No plans or records of its construction have been found. Any information on its date of construction, builder, or plans for this type of tower or ones similar would be greatly appreciated by the project manager for the redevelopment of the site, possibly as an art space or community center. Info: Jacob Vaughan, (832) 576-6926; senorjacob@yahoo.com.

CHAPTER NEWS

Northern and Southern New England held their joint annual conference at Plymouth State College, NH, on Feb. 2. Presentations were on a wide range of New England IA—bridges, machine shops, mills, dams, and the IA of the Shakers.

Northern Ohio toured the Berea Historical Society Museum in March. The chapter, among the SIA's newest, has initiated a newsletter, edited by Ken Lavelle. The most recent issue focuses on the theme of "brick and stone" and includes background information and directions for self-guided tours to a bluestone quarry, a stone-arch bridge, and a 110-yr.-old brick road in northeastern Ohio.

Oliver Evans (Greater Philadelphia) gathered at the Independence Seaport Museum in March to view the exhibits on shipbuilding. Bill Ward, museum educator, led the tour and made a presentation on colonial shipbuilding, tools of the trade, and the William West shipyard in Philadelphia. In April the chapter traveled to Berks County, PA, to visit Bahr Mill, a wood-turning works with belt-driven machinery. The works made, among other things, rakes, baseball bats, and spokes. The group also stopped at the Boyertown Museum of Historic Vehicles, which occupies a part of the former Boyertown Auto Body Works building.

Roebling (Greater NY-NJ) held their annual meeting at Drew Univ. in Jan. Election of officers and a show-and-tell accompanied the meeting.

Three Rivers (Greater Pittsburgh) joined with the Institute for the History of Technology and Industrial Archaeology to sponsor the 2002 Ironmaster Conference in Athens, OH, on Apr. 26-28. Conference activities included a full-day tour of historic furnaces and iron industry sites in the Ironton area, a full-day of paper sessions, and visits to the Buckeye and Vinton furnaces. ■

IA EXHIBITS

A new **O. Winston Link Museum** is slated to be housed in the Norfolk & Western passenger station in downtown Roanoke, VA. Link, famous for his black-and-white (mostly nighttime) images that captured the last days of the steam locomotive and the way people lived around the rails in the late 1950s, used elaborate lighting techniques that still awe photographers today. He spent several years photographing N&W steam locomotives. Link's estate has reached an agreement with the History Museum & Historical Society of Western Virginia and Center on the Square, which owns the passenger station. The project includes renovating the station for exhibit space and offices (*Railway Museum Quarterly*, Fall 2001).

DuPont is celebrating its 200th anniversary with a new exhibit at the **Hagley Museum and Library**, Wilmington, DE. The exhibit will open July 27 and will interpret the company's second 100 years, when it adapted the technology used to make explosives to become a manufacturer of modern polymers. The centerpiece of the exhibit will be a replica of Jeff Gordon's race car, which will be used to illustrate more than 50 products created by DuPont over the past century. The exhibit will also include a 1931 Chevrolet five-window coupe, a replica of a space suit, and a mock-up laboratory in which visitors will be able to do their own experiments on polymers. Hagley is the site of DuPont's original blackpowder works, but the museum has traditionally focused its interpretation on the company's first 100 years, not its growth into a chemicals giant (*Wilmington News Journal*, Feb. 9, 2002). ■

IA ON THE WEB

British Industrial Revolution (www.bbc.co.uk/history). BBC Web site features an industrial history section, including panoramic views, animated inventions, links to industrial history museums, and scholarly articles on such topics as how the Iron Bridge was erected and working conditions in 19th-c. Britain. Once at the site, click on Society and Economy, then Industrialisation.

Historic Bridge Foundation (www.historicbridgefoundation.com). Texas-based group supports historic bridge preservation and education. Web site features news articles and many links to sources of information for historic bridge enthusiasts.

Panoramic Views (www.historicpanoramicmaps.com). A Pittsburgh-area firm holds a collection of some 3,000 panoramic negatives (+/- 8" x 36") of, apparently, every U.S. state plus several foreign countries, ca. 1875-1920, heaviest 1910-15. These cover buildings, city views, events, and much IA: mills, factories, RR yards and scenes, ports and harbors, the Panama Canal, mines, oil fields, etc. Modern prints are sold both from this Web site and from time to time on eBay.

Piece of the Block (www.pieceoftheblock.com) makes available information on New Mexico's industrial past, including bridges, mines, and other sites, with directions to find them. It also offers a general history of coal mining. Links to many history and preservation organizations. Designed and maintained by Bay Stevens [SIA].

St. Augustine Lighthouse (www.staugustinelighthouse.com). Treasure trove of information on the St. Augustine Lighthouse, its

collections, and underwater archeology of the British sloop *Industry*, sunk off the Florida coast in 1764.

Steidle Collection (www.ems.psu.edu/museum/steidle/galleries.html). Virtual gallery features industrial-theme artwork—iron and steel, coal, glass, coke, lime, and oil—in the Steidle Collection at Penn State's College of Earth and Mineral Sciences.

Towboat (<http://koti.mbnet.fi/~soldier/towboat.htm>.) Ever wonder what happens when a boat meets a movable bridge that doesn't get out of the way? Check out this series of remarkable photos to find out about one surprisingly happy ending.

U.S. Steel Gary Works Photograph Collection, 1905-71. (www.dlib.indiana.edu/collections/steel). More than 2,200 digital images document the construction history and operation of what was once the world's largest steel works. Lesson plans, learning objectives, an on-line activities for teachers and grade-school students using the collection.

Readers are cordially reminded to visit the SIA's own Web site at www.sia-web.org. On-line membership applications, gift memberships, and renewals are now available through the SIA's secure Web server.

The SIAN's Web column is compiled from sites brought to the editor's attention by members, who are encouraged to submit their IA Web finds by e-mail: phsianews@aol.com. ■

CALENDAR

2002

June 6: *Digital Recording Strategies for Historic Structures, Brooklyn, NY.* Pre-conference training session at Brooklyn Polytechnic Univ. Emphasis on what works and doesn't work for the challenge of recording large and complex industrial buildings and structures. Co-sponsored by NY Chapter AIA. Info: www.sia-web.org or (202) 619-6370.

June 6-10: *SIA 31st Annual Conference, Brooklyn, NY.* Tours and papers features the Brooklyn waterfront and area industries. Members were mailed registration materials earlier this spring. Info: www.sia-web.org or Mary Habstritt (212) 769-4946; mhabstritt@aol.com.

July 5-8: *National Assn. of Mining History Organizations Conference, Univ. of Wales, Aberystwyth, Wales, UK.* Theme: Application of Waterpower in Mining. Hosted by Welsh Mines Society. Tours and paper sessions. Info: www.namho.org or John Hine, Conf. Sec., The Grottage, 2 Cullis Lane, Mile End, Coleford, Glos. GL16 7QF, UK.

Sept. 3-17: *SIA Study Tour of Sweden.* Limited to 45 members. Registration materials were sent to all members in Feb. At press, registration was near capacity. Info: Christopher Marston (202) 343-1018; cmarston@toad.net; or Robert Vogel (202) 966-1558; toolduller@att.net.

Sept. 6-12: *Assn. for Industrial Archaeology Annual Conference, Edinburgh, Scotland.* Paper sessions and tours. Info: www.industrialarchaeology.org.uk.

Sept. 25-28: *Society for Commercial Archeology Annual Conference, Reno, NV.* Theme: "Reno or Bust: Sin and the American Roadside." Info: www.sca-roadside.org.

Oct. 17-19: *Pioneer America Society Annual Conference, Springfield, IL.* Theme: Cultural Crossroads. Paper proposals requested. Info: Tracey Sculle, Historic Preservation Agency, Old State Capitol, Springfield, IL 62701; (217) 785-4324; Tracey_Sculle@IHPA.state.il.us.

Oct. 17-20: *SIA Fall Tour, Lehigh Valley, PA.* Hosted by the National Canal Museum, Easton, PA. Info: Lance Metz, NCM, 30 Centre Sq., Easton PA 18042; (610) 559-6613.

Oct. 17-20: *Society for the History of Technology Annual Meeting, Toronto, Ontario.* Info: www.shot.jhu.edu.

2003

Jan. 14-19: *Society for Historical Archaeology and the Advisory Council on Underwater Archaeology Annual Conference, Providence, RI.* Theme: Trade and Industrialization. Paper proposals requested. Info: www.sha.org.

Jan. 20-24: *First International Conference on Construction History, Madrid, Spain.* Hosted by Escuela Tecnica Superior de Arquitectura de Madrid (School of Architecture in Madrid). Info: www.aq.upm.es/construction-history/

Mar. 26-30: *American Society for Environmental History Annual Meeting, Providence, RI.* Paper proposals requested by Sept. 1. Info: www2.h-net.msu.edu/~aseh/. or Ravi Rajan, ASEH Program Chair, Dept. of Environ. Studies, Univ. of CA, Santa Cruz, CA 95064; srrajan@cats.ucsc.edu.

May 29-Jun. 1: *SIA 32nd Annual Conference, Montreal, Quebec.* Info: Patrimoine Industriel Montréal 2003, 2050 rue Amherst, Montréal QC H2L 3L8, Canada; (514) 528-8444; fax, 528-8686.

July 10-14: *TICCIH 12th International Congress, Moscow, Russia.* Theme: Preservation of industrial heritage and rehabilitation of old industrial centers. Paper proposals requested. Post-conference tours to mining and metallurgical sites in the Urals. Info: Eugene Luganov, Inst. of Material Culture, Box 65, Ekaterinburg, B-109, Russia; luganov@online.ural.ru; www.museu.mNACTEC.com/TICCIH. ■

Department of Social Sciences
Michigan Technological University
1400 Townsend Drive
Houghton MI 49931-1295

**SOCIETY FOR
INDUSTRIAL
ARCHEOLOGY**

Address Service Requested

Presorted Standard Mail
U.S. POSTAGE
PAID
Permit No. 110
Hopkins, MN