



# SOCIETY FOR INDUSTRIAL ARCHEOLOGY

## NEWSLETTER

Volume 37

Winter 2008

Number 1

### SAVING STEEL *SIA Grant Helps Western Reserve H.S. Process Company Records*

The American steel industry has had a tumultuous history, with astounding peaks and devastating valleys. During the 20th century, the steel industry was one of the prime drivers of the economy, and in certain areas of the country, entire cities owed their livelihoods to the sprawling mills that dominated their skylines. By the 1980s, radical change was wracking the industry as longtime companies faced downturns, offshore competition, labor strife, increasing regulation, and complacent management. Storied companies disappeared into mergers or closed. While the industry seemed to right itself by the 1990s, it proved only temporary. Another downturn in the early 2000s resulted in the loss of still more companies that entered bankruptcy, closed, or were bought by foreign owners.

As these changes were playing out, being in the right place at the right time permitted the Western Reserve Historical Society (WRHS) in Cleveland to play a significant role in saving some of the proud heritage of the steel industry. During the late 1990s, WRHS had been building a relationship with LTV Steel to collect oral histories from retired workers for a proposed exhibit. After a time, the company's representatives saw that WRHS wanted to preserve the history of the steel industry in Cleveland. In 2000, LTV entered their second bankruptcy, and though company officials pledged to find a way out, longtime employees were skeptical and felt that the company would close.

One day while WRHS staffers were working with LTV's retirees at the headquarters of the company's Cleveland

*(continued on page 2)*

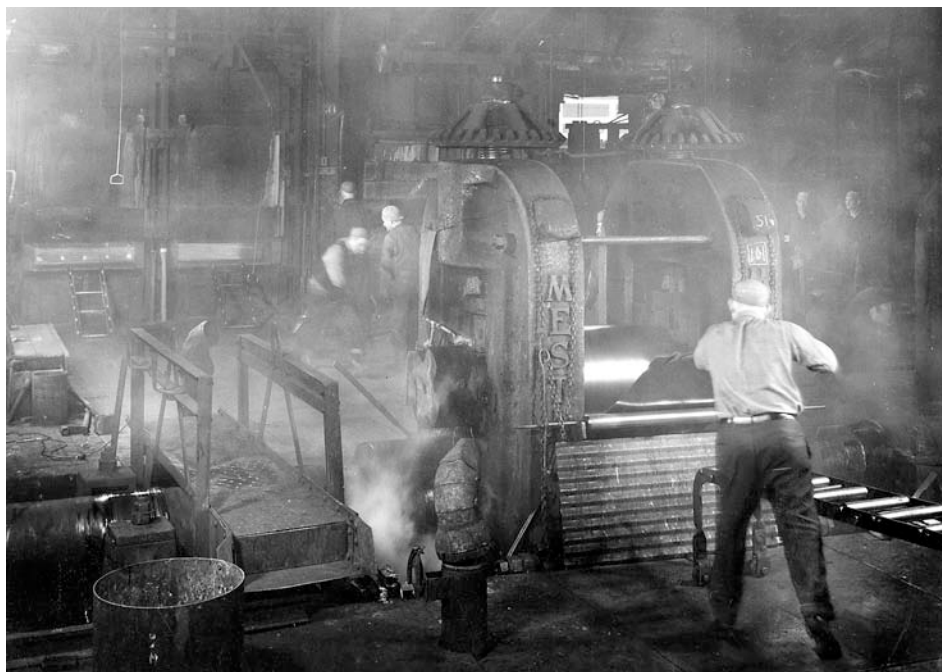

All photos courtesy WRHS

Republic Steel's Warren Works, ca. 1930. Hand-rolling silicon-steel sheets.

#### In This Issue:

- *S. S. Meteor* Project
- Automatic Block-Signal System, Part 2
- SIA Slate of Candidates
- General Tools Award Nominations
- Port of Richmond Diesel Locos
- Tod Engine Reaches Milestone

Works, LTV's community relations director asked if WRHS would like to have "some old pictures" and showed them box after box of photographs, negatives, and slides in a dusty basement room. Historians dream of finding such an amazing collection, and WRHS immediately accepted the offer.

The collection had approximately 43,000 negatives and thousands of 35mm slides from Republic Steel, hundreds of photos from LTV Steel, and hundreds, perhaps even a thousand or more, rare black-and-white photos of Otis Steel in Cleveland from before the company was purchased by Jones & Laughlin in 1942. In total, there are probably 50,000 images, most dating from the 1930s or later. Overall, the quality of the photography is quite good, and some images are absolutely outstanding examples of industrial photography.

After the photo collection was donated, many of the longtime staffers at LTV felt that more should be saved, even as company layoffs began occurring with frequency, so they sent more papers and artifacts to WRHS. The best sup-

porter was a longtime administrative assistant in the corporate headquarters, who steadily fed boxes of materials. Then she learned that she and nearly all the remaining corporate staff were to be laid off as the company looked to liquidate its assets and go out of business completely. She invited WRHS to a farewell picnic at LTV's headquarters, which were in a former Republic Steel building. Company officials wanted to remove the time capsule that Republic Steel had put in the cornerstone, and give the contents to WRHS.

The capsule was removed, opened up, and immediately water poured out. Over the past 50 years, the building had shifted and cracked the time capsule case. Everything inside was ruined. So there was nothing to collect, but the WRHS staff stayed for the picnic. While eating, the staff met the LTV personnel in charge of records retention. Although they pointed out that their job was to destroy the old company records, WRHS asked them if these records could go to them instead. LTV inquired with the company lawyers, and a few days later, they called and offered 45,000 boxes!

That was a staggering amount, more than anything offered to WRHS in its 140-year history. Quick action was required because whatever wasn't taken would be shredded. WRHS was sent a spreadsheet inventory spanning hundreds of pages in the tiniest of fonts. Aided by magnifying lenses, staff went over the inventory, line by line. This work was greatly aided by Benjamin Blake, then WRHS's Assistant Curator of Manuscripts, and currently archivist at the Hagley Museum & Library, who not only had done a good deal of research in steel and labor history, but was also a former steelworker. Pouring over the inventories, staff checked off boxes that looked like they had valuable materials, knowing full well what wasn't check off would be destroyed. Final selections resulted in roughly 3,800 boxes being transferred to WRHS where Ben packed them into every available storage area.

The *SIA Newsletter* is published quarterly by the Society for Industrial Archeology. It is sent to SIA members, who also receive the Society's journal, *IA*, published biannually. The SIA through its publications, conferences, tours, and projects encourages the study, interpretation, and preservation of historically significant industrial sites, structures, artifacts, and technology. By providing a forum for the discussion and exchange of information, the Society advances an awareness and appreciation of the value of preserving our industrial heritage. Annual membership: individual \$50; couple \$55; full-time student \$20; institutional \$50; contributing \$100; sustaining \$150; corporate \$500. For members outside of North America, add \$10 surface-mailing fee. Send check or money order payable in U.S. funds to the Society for Industrial Archeology to SIA-HQ, Dept. of Social Sciences, Michigan Technological University, 1400 Townsend Drive, Houghton, MI 49931-1295; (906) 487-1889; e-mail: [SIA@mtu.edu](mailto:SIA@mtu.edu); Website: [www.sia-web.org](http://www.sia-web.org).

Mailing date for Vol. 37, 1 (Winter 2008), Feb. 2008. ISSN 0160-1067. If you have not received an issue, apply to SIA-HQ (address above) for a replacement copy.

The *SIA Newsletter* welcomes material and correspondence from members, especially in the form of copy already digested and written! The usefulness and timeliness of the newsletter depends on you, the reader, as an important source of information and opinion.

**TO CONTACT THE EDITOR:** Patrick Harshbarger, Editor, *SIA Newsletter*, 305 Rodman Road, Wilmington, DE 19809; (302) 764-7464; e-mail: [phsianews@aol.com](mailto:phsianews@aol.com).



*Otis Steel, ca. 1935. Tapping the open hearth.*

As WRHS staff began to sort through the boxes, they found that the archival collection included records from LTV, Republic Steel, Jones & Laughlin, Youngstown Sheet & Tube, and a variety of subsidiary operations owned by these companies all over the U.S. A grant from the National Endowment for the Humanities, which could help fund the processing of the collection, was applied for emphasizing that WRHS would process the entire collection, but then break it up along geographical and company lines for distribution to regional archives where a particular company was headquartered or had operated. This idea resonated with the NEH, and they awarded the grant. It was a matching grant, so WRHS was required to raise money from a number of other sources, including an SIA preservation grant.

WRHS curator Margaret Burzynski-Bays led a team that organized the collection while weeding out duplicate and irrelevant materials. Staff found that the bulk of the archival collection was from Jones & Laughlin, and had materials dating back to the formation of the company. There were sizable amounts of Republic Steel and LTV Steel records, but only a small amount from Youngstown Sheet & Tube. The collection had old maps of company facilities, blueprints and engineering drawings of equipment and facilities, ledger books for production records from the 19th and 20th centuries, correspondence, employee pay ledgers, company advertising materials and publications, extensive labor-relations records, and a variety of employee records, including tens of thousands of employee folders from Jones & Laughlin facilities in Pittsburgh from the 1920s to the 1960s.

The processing of the collection was completed on time and on budget in two years. Once completed, the collection was broken up into three sub-collections: Jones & Laughlin Steel records, which were sent to the Historical Society of Western Pennsylvania in Pittsburgh; the Youngstown Sheet & Tube records, which were sent to the Ohio Historical Society's Youngstown Center of Industry & Labor; and the Republic Steel and LTV Steel records, which were retained by WRHS. The photographic collection remained in Cleveland, since all the photos were from Cleveland-based Republic Steel, Otis Steel, or LTV Steel.

As the project wound down, WRHS revisited an idea from early on: creating a book from the photographic collection. Kent State University Press was intrigued because of its regional history focus, and agreed to publish it. *Steel*



*Corrigan McKinney Steel, 1914. Construction of Blast Furnace #3 with older style furnace in the background.*

*Remembered* describes the saving of the collection and the photographs, and briefly covers the history of the three featured companies—Corrigan McKinney Steel, Otis Steel, and Republic Steel. For the Corrigan McKinney chapter, photos came from an album of steel mill construction photos from 1913-1916. The Otis Steel photographs are from the 1930s, and the Republic Steel photos range from the 1930s to the 1960s and show all phases of steelmaking. Altogether there are more than 100 photos in the book, which is available for purchase from the press (<http://upress.kent.edu>), at other online booksellers, and many bookstores.

*Christopher J. Dawson*

## SIA Industrial Heritage Preservation Grants

### Deadline for Applications: March 31

The SIA awards grants of up to \$3,000 to support projects that document or preserve our industrial heritage. Information can be found at [www.siahq.org/grants/about.html](http://www.siahq.org/grants/about.html). ■

# Whaleback Steamship Meteor

## SIA Preservation Grant Update

In the small northern Wisconsin city of Superior, a strange looking ship rests in the sand along the shore of the Duluth-Superior harbor that opens into Lake Superior. She is the S.S. *Meteor* (tour site—2000 SIA Annual Conference), last of the whaleback ships built by Duluth entrepreneur Alexander McDougall. McDougall conceived of the whaleback ship as a type that would revolutionize the shipping industry. He patented the idea and founded the American Steel Barge Co. to build and operate the ships. A total of 29 whaleback barges and 15 whaleback steamships were built between 1888 and 1898. Evolving ship-design technology soon made the concept obsolete and no whaleback ships were built after 1898.

*Meteor* was built in 1896 as the *Frank Rockefeller* and hauled bulk cargos for American Steel Barge and later iron ore for U.S. Steel's Pittsburgh Steamship Co. In 1925 she was sold to new owners and renamed *South Park*. In the 1930s she hauled automobiles on a specially built flat deck. In 1943, she was converted to a tanker and renamed *Meteor*. She hauled refined petroleum products around the lakes until she was retired in 1969. In 1972 the ship was moved to Superior and opened as a city-owned museum.

For the past two years, a small group of researchers has been studying the ship, her construction, and significance to plan for her future. While much has been done by volunteers, grants from organizations including the SIA have allowed the group to hire professionals when required.

*What Is a Whaleback Ship?* The term “whaleback” refers to ships built to a design patented by Alexander McDougall. All whalebacks share a number of defining features:

- A spoon-shaped bow. The first whaleback ship (Barge 101) had a conical-shaped bow intended to reduce the tendency of a barge to yaw when towed. The conical shape was refined to a spoon shape on later barges and

McDougall chose to retain it when he began to build powered vessels.

- Low freeboard. To minimize weight, McDougall eliminated the forecastle deck usually found on ships, and designed his whalebacks with a straight sheer. (The deck line did not rise as it approached the ship's bow and stern.)
- Arch-shaped decks. The arch shape allowed the deck to shed water and permitted a lighter structure, further reducing hull weight and construction cost.
- Narrow stern. Unlike conventional Great Lakes ships built with wide, fan-shaped sterns, whalebacks were built with narrow sterns that reduced the tendency of the stern to lift to a passing wave.
- High-integrity hatches. Since there was no forecastle or forward deck sheer to protect them, conventional hatches with wooden covers would not have provided sufficient watertight integrity. Instead, all whalebacks were built with steel-plate hatches secured with bolts and sealed with gaskets.
- Turrets. To provide entry below deck, openings for whalebacks were placed in turrets erected on top of the hull. *Meteor* had four: one in the bow, and three in the stern. The bow turret also provided a protected space to house the anchor windlass, and the stern turrets provided an elevated foundation for the pilot house, the galley, and crew quarters.
- Other features: Whalebacks also included several features aside from the hull that were invented and patented by McDougall. Included were special anchors, watertight skylights, and towing and anchor handling fairleads.

*What Caused the Demise of the Whaleback?* At first whalebacks were able to compete in the rapidly expanding iron-



The S.S. *Meteor* enters Duluth harbor in 1969.



The upper level of the engine room.

ore trade. Their light hull structures allowed a high percentage of displacement facilitating the transport of heavy cargos, but as time went by conventional “straight-deck” ships grew in size. While whalebacks were often as long as these, they were narrower, resulting in less displacement and capacity. The whalebacks became less and less competitive. McDougall obtained financing for American Steel Barge from John D. Rockefeller. When the panic of 1893 hit, McDougall lost control to Rockefeller, and the whalebacks lost their most ardent promoter.

*Why Is the Meteor Significant?* During the last years of the 19th century, naval architects were experimenting with many radical hull designs in an attempt to design the ideal merchant ship. David Arnot, a maritime historian, states, “The period from 1890 to 1910 was noteworthy because of the introduction of many types of ships that differed from conventional design ... While some of these types are no longer built, they represent an important stage in structural development and exemplify the increasing attention on the part of shipbuilders to turn out ships that were economical in construction and in maintenance and operation for their particular service.” *Meteor* is the world’s last known surviving example of these novel ships.

The whalebacks also inspired the design of another novel type, the turret ship. One of the first whaleback steamships, the *Charles Wetmore*, was designed to operate in salt water. She passed through the St. Lawrence River rapids and sailed to Europe, where she created much interest. The Doxford yard in England modified the whaleback design to build a ship known as the turret ship of which over 170 were built. None of these are known to exist.

*Meteor*’s structural design is also of interest. During the 1890s, large riveted iron and steel hulls were still evolving, and one of these can still be seen aboard *Meteor*. The ship also retains its well-preserved reciprocating steam propulsion plant, designed for use in fresh water. And the *Meteor*

is the last survivor of the 112 ships from various fleets merged in 1901 to form the Pittsburgh Steamship Co., the largest fleet on the Great Lakes and one of the largest merchant fleets in the world.

#### *What Have We Accomplished So Far?*

- A qualified marine surveyor has made a detailed study of the ship’s condition. His report documents each compartment and lists repair work that is urgent and work that can be performed at a later date. The surveyor was prevented from surveying some areas as the ship is buried in sand up to about the 11-ft. waterline. We are considering excavating representative areas of the hull to allow further exploration.
- A qualified marine engineer has completed a detailed study of the ship’s machinery, its evolution, present condition, and state of the art of marine engineering on the Great Lakes in the 1890s.
- We have acquired copies of all known drawings used by American Steel Barge and have published a feature length article discussing them in the *Nautical Research Journal* (Vol. 52, No. 3). A draftsman has been added to our team to prepare additional drawings based on archival materials.
- An engineering firm has been hired to prepare conceptual plans for the ship’s preservation and display.

#### *What Do We Still Not Understand?*

- Exactly what role did McDougall play in American Steel Barge after the 1893 takeover by the Rockefeller interests?
- Who were the talented individuals who helped McDougall to develop the whaleback?
- *Meteor* was modified many times during her long life. What modifications were made and when?

C. Roger Pellett



*The S.S. Meteor, 2007.*

# Signal Aspects and Indications within the Automatic Block System, Part 2

## *The Railroad Age Gazette 1921-23*

The University of Vermont's historic preservation program offers a course taught by Robert McCullough [SIA] that requires students to examine old technical journals. The students select a topic, and then evaluate how the journals covered it over time. The block signal article by graduate Sarah Grawly was an outgrowth of that exercise; besides offering a clear and insightful analysis, it illustrates a teaching method for developing an appreciation for the material culture of American industrialization and the use of primary sources. Part 1, 1887-91 appeared in SIAN (Fall 2007).

A comparison of *The Railroad Gazette* from 1887 to 1891 and *The Railway Age Gazette* from 1921 to 1923 reveals the changing nature of the railroad industry. Articles published in the early 1920s demonstrate that the automatic block-signal system continued to be a significant subject within the professional discourse; however, the system's essential focus had changed. While the early motivation for the automatic block-signal system was to provide a safeguard against collisions for higher-speed train travel, the concentration by 1920 was decidedly economic.

Automatic block signaling permitted trains to move more quickly and efficiently, thereby increasing capacity and profit. Moreover, the railroads had begun to recognize the actual costs of train delays. On June 30, 1906, Congress authorized the Interstate Commerce Commission to investigate and report on block signals and automatic controls.

An ICC committee gathered the first hard evidence on the extent of their use and the industry started to grasp the vast economic potential. In 1921 James B. Latimer, signal engineer for the Chicago, Burlington & Quincy, wrote, "I do not believe that there is any improvement which railroads can make today which will give as large and direct a return for the money in the speeding up of train movements as automatic block signals." As railway men began to show a keener appreciation of the system's value, railroads feverishly built and improved automatic block signals. This swift expansion manifested itself on the American landscape in the form of new and abundant railroad signal apparatus.

The basic principles of the automatic block system remained unchanged between the late 1880s and early 1920s. Tracks continued to be divided into blocks governed by closed electric circuits that regulated signals for each section. The automatic block persisted as the only system in which the train itself controlled the signals protecting its movement. The technology changed only slightly as engineers explored new types of batteries, current values and circuitry, and electric motors began to replace electro-pneumatic powered signals by the turn of the century. The system's most visible element within the landscape, however, the signal aspect, had been transformed dramatically by the 1920s.

*Semaphore Signals.* The semaphore, the mechanical apparatus that used blade position to indicate the presence of a



*Four-track signal bridge showing lower-quadrant semaphore signals, NY Central & Hudson River RR (The Railroad Signal Dictionary, 1908, p. 102)*



Upper-quadrant semaphore signals (Jan. 7, 1921, p. 160).

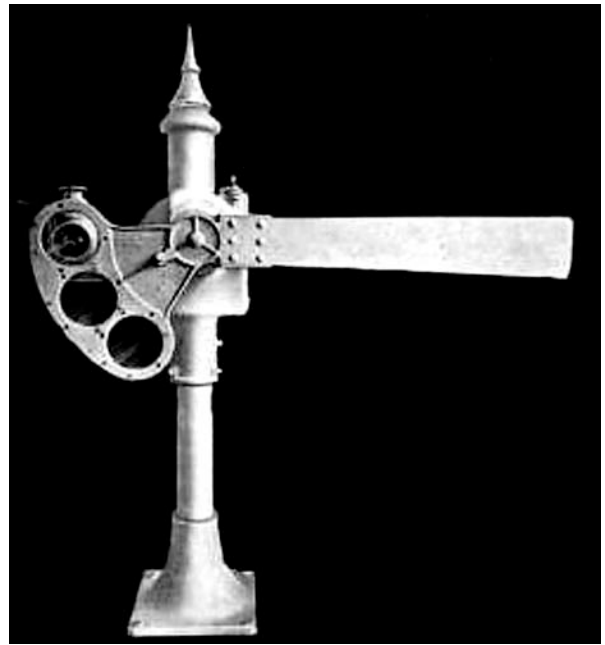

Three-aspect, lower-quadrant semaphore signal with lenses for colored aspects, General Railway Signal Co. (The Railroad Signal Dictionary, p. 76)

train in a given block, was the primary signal type within the early phases of the automatic block-signal system. Despite its success, it soon became evident that semaphores had several deficiencies. Therefore, the semaphore underwent many changes in a very short time. One of the first was an expansion of the positions, known as “aspects,” that its blades could produce.

In 1900 the Pittsburgh, Fort Wayne & Chicago introduced a new form of semaphore, the three-aspect signal, in which a semaphore arm could be shown in three different positions, thus expanding the number of meanings or “indications.” The three-aspect signal was placed at the beginning of a block and was composed of a single semaphore arm. A horizontal position indicated “stop”; an arm in the vertical position indicated “proceed,” that both the immediate and succeeding blocks were clear; and an inclined light indicated “approach,” that the immediate block was clear but the following signal indicated stop. Although three-aspect signals were already in use on some American railroads, this was the first instance within the automatic block system.

Many three-aspect semaphore signals utilized the same lower-quadrant arm pivot arrangement employed on the early semaphores. In a lower-quadrant signal, the arm lies along the post when in the vertical position and pivoted upward to become perpendicular to the post. In the first decade of the 20th century, signal engineers developed the fail-safe upper-quadrant signal, in which the arm pivoted down. This new arrangement soon became standard on American railways.

In addition, it became clear that the semaphore signal’s visibility had become a problem. Companies required max-

imum access to their tracks, but the arm position could be perceived only in daylight, therefore rendering the automatic block system ineffective at night. Signal engineers responded by adding colored aspects to semaphore arms. The colors were produced by an apparatus known as a “spectacle” that held different colored lenses near the semaphore’s pivot. As the arm moved, the lenses passed in front of a lamp projecting a colored light, depending on the angle of the semaphore. These aspects were easily discernable in the darkness.

The indications suggested by the colored aspects themselves evolved. A *Railroad Signal Dictionary* reported that before the turn of the century, “the long-standing and general practice on American railroads at night [was] white for clear, green for caution, red for stop.” However, as color aspects became more widespread, indications began to change. In the first decade of the 20th century, a second scheme came into favor: green for clear, yellow for caution, red for stop.

Although a great improvement over strictly daylight semaphores, these illuminated signals were nevertheless seen as imperfect devices. Semaphore signal lamps were lit by oil and, therefore, did not produce a color that could be seen in daylight. As a result, both semaphore arms and colored lenses had to be used together to ensure adequate signaling. The combination of two different aspects was awkward and complicated, and their numerous and heavy moving parts made for frequent and expensive maintenance. By 1921, despite enhancements, the semaphore was growing obsolete. Advancements in technology and the constant need for greater track capacity compelled engineers to seek new solu-

(continued on page 8)

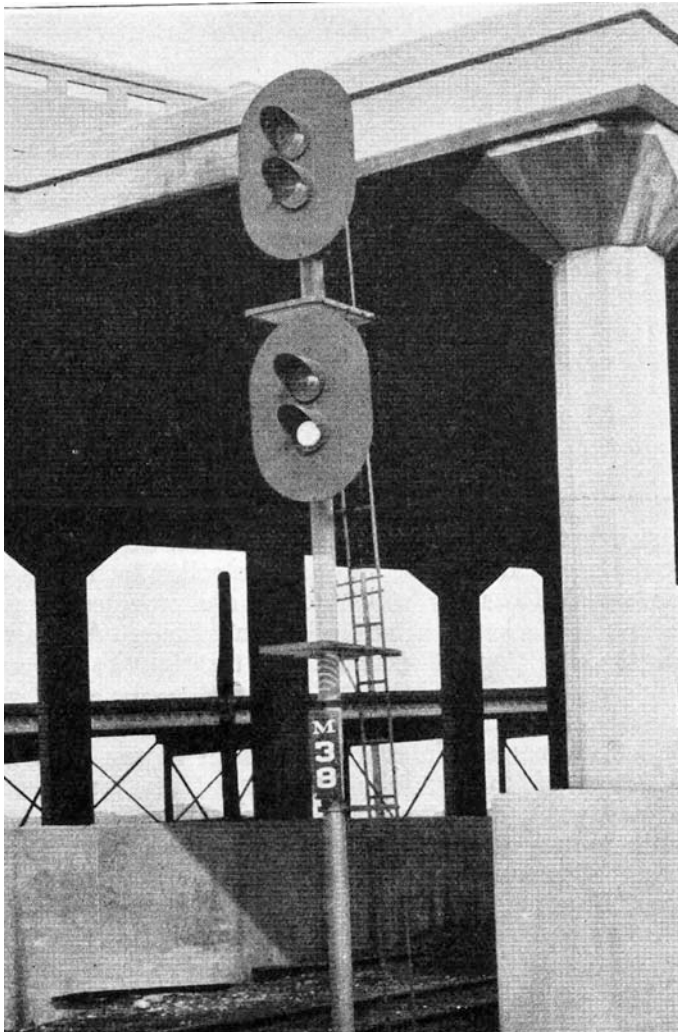

Union Style-L color-light signal on the DL&W (Dec. 23, 1922, p. 1187)

tions. Railroads abandoned semaphores and turned instead to three other types of signal apparatus: the color-light, position-light, and color-position-light. Because development was so accelerated, signaling did not evolve uniformly. As a result, each railroad developed its own, slightly different system of aspects and indications.

*Color-Light Signals.* It was not until electric lamps became available that a light with sufficient intensity for daytime visibility replaced the relatively dim, high-maintenance oil lamp. Electric lights used the same aspects by both day and night. Improvements to lamp filaments in 1913 opened the door to a wealth of new invention. By 1920, the night aspects of semaphore signals had essentially been transformed into the day and night aspects of the new color-light signals. In effect, the wide availability of electricity precipitated the demise of the semaphore signal.

In 1922, a *Railway Age Gazette* article about the introduction of the color-light signal on the Delaware, Lackawanna & Western (DL&W) remarked, "Ten years ago there were only two tracks across the Meadows, and traffic on these was protected by two-position, two-arm semaphore signals." The DL&W installed Union (Switch & Signal Co.) Style-L color-light signals throughout. These consisted of two sets of vertically paired lights, one atop the other, mounted on posts or signal bridges. Each aspect contained a concentrated filament lamp and colored lens: red and yellow above and yellow and green below. The illumination of the lamps in a certain pattern indicated specific directions for trains. For example, red over yellow was a "stop and proceed" signal, while yellow alone indicated "approach next signal prepared to stop." Today, color-light signals remain the most popular form of railway signal in the U.S.

*Position-Light Signals.* Position-light signals emerged just before 1920 as an alternative to the illuminated semaphore

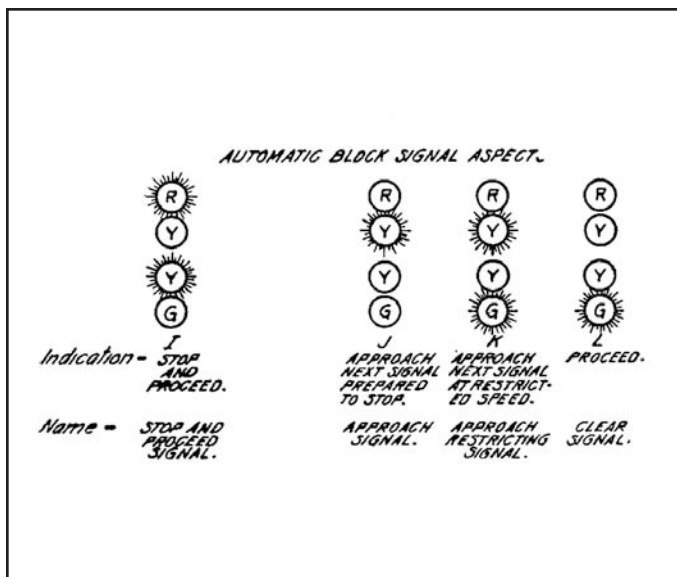

Color-light aspects on the DL&W (Dec. 23, 1922, p. 1186)

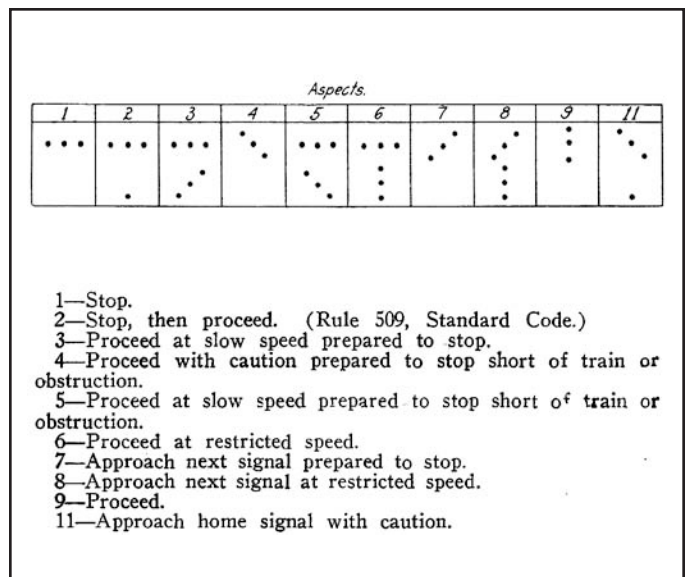

Position-light aspects on the PRR (Sept. 17, 1921, p. 539)



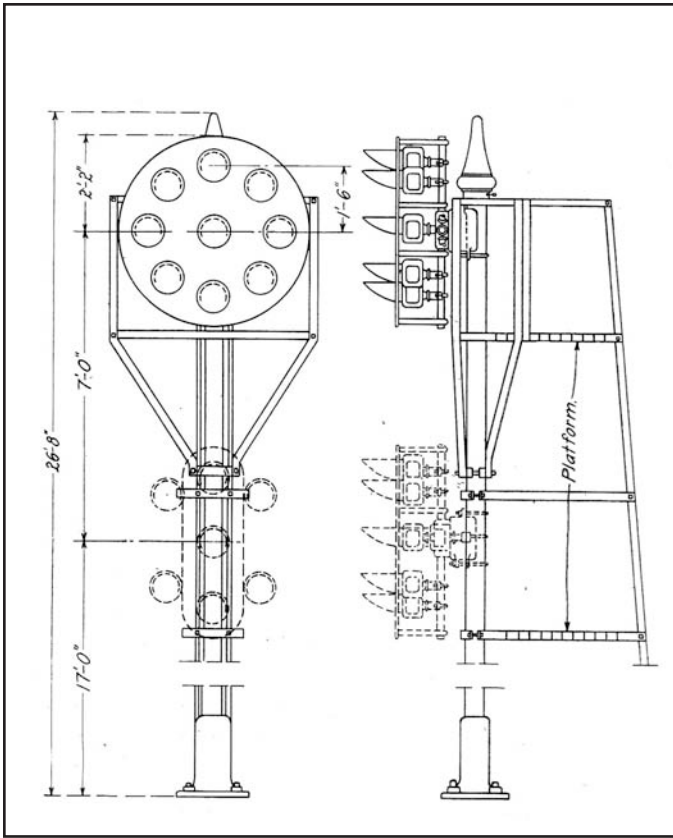

Position-light signal on the PRR (Sept. 17, 1921, p. 538)

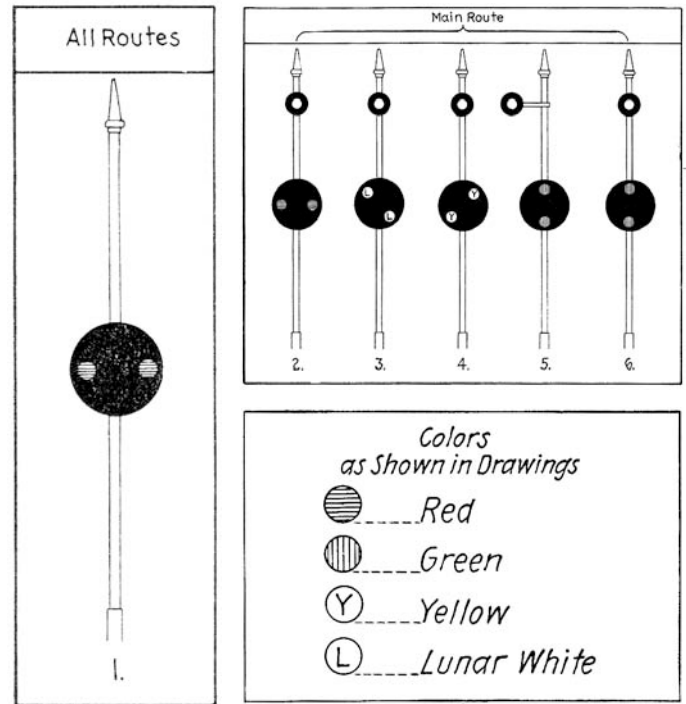

Standard color-position-light signals on the B&O. 1—Stop; 2—Stop then proceed; 3—Proceed prepared to stop short of train or obstruction; 4—Proceed prepared to stop at next signal; 5—Proceed, approach next signal at restricted speed; 6—Proceed (Feb. 21, 1925, p. 456)

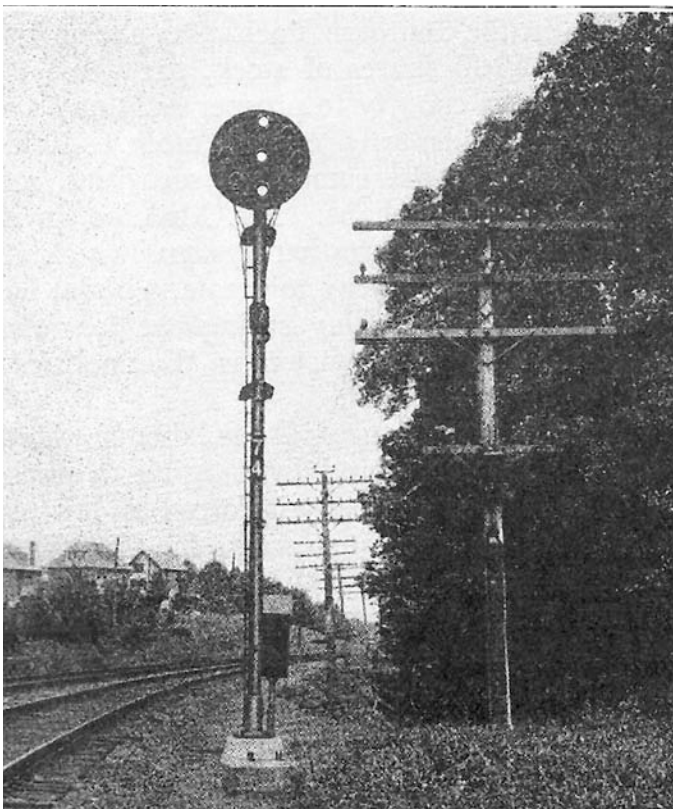

Position-light signal on the PRR (Sept. 17, 1921, p. 539)

signal. Pennsylvania RR (PRR) signal engineer A. H. Rudd, along with William Churchill of the Corning Glass Works, first began experimenting with position-light signaling in early 1914. In early 1915, the *Railway Age Gazette* reported that the PRR “will introduce, in place of semaphore block signals, a novel arrangement of lights, uncolored, by which both motion and color will be done away with, the lamps being used day and night.” The PRR refined the design over the next few years, testing different arrangements of electric lights and backgrounds until 1921, when a new design was officially adopted. By this time, the position-light signal was already a well established feature with nearly 2,000 in service. Throughout its active life, the position-light signal continued to be chiefly identified with the PRR.

With the position-light signal, the arrangement of the illuminated lights, not their color, determined the indication. The signal on the PRR consisted of a simple frame and background carrying uncolored electric lights in rows of no more than three lights each. The presence or lack of a train within a block caused the lights to be automatically illuminated in one of four different aspect patterns. In each aspect, the individual lights connected visually to form a line at an angle corresponding roughly to the positions of a semaphore blade.

The position-light signal was advantageous in several

(continued on page 23)

# “Change is the Constant”

SIA Annual Conference • San José, May 29–June 1, 2008

Whether it's the geological change that has shaped the entire Bay Area, or the constant pace of innovation and daring, nothing better describes the Bay Area and Silicon Valley than “Change is the Constant,” the theme for the 2008 SIA Annual Conference. Change takes many forms: economic, environmental, technological, and social, all of which occur at an ever increasing pace here. The challenge for IA is how to capture this dynamic environment, and to utilize the forces of change to further the research and public outreach that are the core of the SIA mission. Come to San José, where Change is the Constant!

The Samuel Knight Chapter is helping to organize the event and tours are preliminarily planned for the New Almaden mercury mines and smelters, WWII-era military installations, shipyards, automotive plants, and early computer industry shrines, including the Hewlett-Packard garage and Shockley Semiconductor. The conference hotel will be the Sainte Claire in downtown San José. Check the conference Web site for more details as plans evolve: <http://knightsia.org/sia2008>. Registration materials will be mailed to all members in March.

## STUDENT TRAVEL SCHOLARSHIPS

The SIA awards travel scholarships to help full-time students and professionals with less than three years of full-time experience to attend annual conferences. Those interested in applying for a travel scholarship to attend the annual conference in San José should submit a concise letter outlining their demonstrated interest in and commitment to industrial archeology or a related field, and one letter of reference. **Deadline for applications is Mar. 21, 2008.** Info: Patrick Harshbarger, SIA Scholarships, 305 Rodman Rd., Wilmington, DE; (302) 764-7464; [phsianews@aol.com](mailto:phsianews@aol.com). Notice of awards will be made by Apr. 15.



Jet Lowe, HAER, 2002

The SIA plans to visit the S.S. Red Oak Victory, one of two surviving Victory Ships. She was built at the Kaiser Shipyards, and served in WWII, the Korean War, and the Vietnam War. She is now docked at the Rosie the Riveter National Historical Park in Richmond.

## CHAPTER NEWS

**Northern Ohio** held its annual meeting in December at the Cleveland State University Library. Chris Dawson presented on the history of Otis Steel, Corrigan Steel, and LTV Steel (see article in this issue). The chapter reports an all-time high of 47 members.

**Oliver Evans** (Greater Philadelphia) marked its 20th annual filmfest in December. Lance Metz presented films on the making and shaping of alloy steel, anthracite coal, and 1930s views of the Delaware Canal. In January, the chapter held its annual meeting at the Union League of Philadelphia, established in 1862 as an organization for patriotic mechanics.

**Roebling** (Greater NY-NJ). Good news was received on the preservation front in October when the New York City

Landmarks Preservation Commission voted unanimously to designate the five remaining buildings of Brooklyn's pencil factory as the Eberhard Faber Pencil Co. Historic District. The chapter's annual meeting was in Paterson, N.J. and included a tour of the Paterson industrial historic district and the Paterson Museum, as well as the business meeting.

**Southern New England** toured the historical collections of the Harvard Business School's Baker Library in November.

**Support Your Local Chapter.** For info on a chapter near you or to start one, contact Jay McCauley, SIA Director, Local Chapter Chair ([mccauley3@sbcglobal.net](mailto:mccauley3@sbcglobal.net)) or check out the local chapters section of the SIA Web site ([www.sia-web-org](http://www.sia-web-org)). ■



# SOCIETY FOR INDUSTRIAL ARCHEOLOGY

## NEWSLETTER

### PUBLICATIONS OF INTEREST

Vol. 37, No. 1

Winter 2008

COMPILED BY

Mary Habstritt, New York, NY; and Patrick Harshbarger, SIAN editor.

#### GENERAL INTEREST

- ◆ Richard Jackson. **Recognizing Emerging Environmental Problems: The Case of Chlorinated Solvents in Groundwater.** *T&C*, Vol. 45, 1 (Jan. 2004), pp. 55-79. Vapor-degreasing agents and chlorinated solvents were introduced by many manufacturers in the 1930s to degrease metal parts. Contamination of groundwater was not recognized until the 1970s.
- ◆ Robert Nelson, ed. **The Directory of American Toolmakers.** Early American Industries Assn. ([www.eaianfo.org](http://www.eaianfo.org); 167 Bakerville Rd., S. Dartmouth, MA 02748) 1st ed., 1999; CD 2007. \$35 ppd. This CD contains a complete reprint of the first edition of the directory, listing about 14,000 toolmakers in Canada and the U.S. before 1900. Searchable text, a new introduction with links to allow easy access to the various sections of the directory, and an index to the EAIAs journal *Chronicle*.
- ◆ Janet Siskind. **Rum and Axes: The Rise of a Connecticut Merchant Family, 1795-1850.** Cornell Univ. Pr., 2001. 191 pp. \$35. The Watkinsons of Middletown made wealth in the West Indies trade, then began transferring that capital to manufacturing to become prominent factory owners in Hartford. A case study in American industrialization. *Rev.: T&C*, Vol. 45, 1 (Jan. 2004), pp. 185-86.
- ◆ Sabina Strachan. **Industrial Archaeology Workshop in Baia Mare, Romania.** *IA News* 132 (Spring 2005), pp. 2-4. Preserving lead mines, waterpowered rural mills, and a logging railway.
- ◆ **TICCIH Bulletin** No. 38 (Winter 2007) features Janet Wright, *Balancing Conservation and Adaptive Reuse: The Distillery District, Toronto, Canada*; Jonathan Truillet, *Industrial Heritage and Business Patronage: New Deal and New Problems* (case of Heineken France sponsoring an exhibit on breweries, not out of pure interest in history but as marketing strategy); Hans-Peter Bärschi, *Tourism—Business Methods to Preserve Historic Railways and Industrial Monuments* (Swiss industrial sites and landscapes in Zurich Oberland), as well as other notes on the industrial heritage from around the world. Quarterly with membership. Info: [www.mnactec.com/ticcih](http://www.mnactec.com/ticcih).
- ◆ Michael Williams, Richard Cahan, and Bruce Moffat. **Chicago: City on the Move.** City Files Press ([www.cityfilespress.com](http://www.cityfilespress.com)), 2007. About 250 photos. \$39.95. Makes available for the first time a selection of photos from the Chicago Transit Authority archives, showing the construction and operation of streetcars, railways, and buses, and in the process the growth of the city itself. Beautifully produced.

#### POWER GENERATION

- ◆ Denis Baker. **Swannington Heritage Trust and the Hough Mill Project.** *IA News* 132 (Spring 2005), pp. 5-6. Restoration of ca. 1800 windmill in Leicestershire, England.
- ◆ Irwin T. Clark, Jr. **The Light from the River: Central Maine Power's First Century of Service.** Central Maine Power Co., 1999. Illustrated corporate history captures efforts to develop hydropower in rural Maine.
- ◆ Gilbert G. Cooke [SIA]. **The Story of the L Street Power Station, 1898-2006.** Exelon Corp., 2007. 105 pp., illus, diags., tables, biblio. Avail. \$30 ppd. from [gilcooke@ieee.org](mailto:gilcooke@ieee.org). Extensively illustrated and attractively produced history of the generating plant established by Boston Electric Light and now operated by Exelon. Each chapter covers a phase in the station's development from original construction in 1898 through five successive expansions to 1965. Included are the chimneys with a discussion of the pioneering 1937 gas scrubbers designed to reduce emissions. All of the details receive coverage from switchgear buildings to boilers, coal stokers, and architecture.
- ◆ Jeff Goodell. **Big Coal: The Dirty Secret Behind America's Energy Future.** Houghton Mifflin, 2006. 324 pp., \$25.95. Indictment of the country's "biggest, most powerful and most antiquated industries." Follows the path of coal from mines in W.Va. and Wyo., how it is extracted and transported, to power plants where it is burned for electricity, to the resulting environmental impacts. New technologies for cleaner electricity are also examined. *Rev.: NY Times* (June 21, 2006).
- ◆ Elizabeth Mann, illus. by Alan Witschonke. **The Hoover Dam: The Story of Hard Times, Tough People and the Taming of a Wild River.** Mikaya Pr., 2006. 48 pp., illus. \$9.95. Part of the Wonders of the World series for children, this book is aimed at ages 9-13. Describes the danger, suffering, courage, and genius that went into building one of America's most famous landmarks and how important it was as a generator of jobs during the Depression.
- ◆ John F. Wasik. **The Merchant of Power: Sam Insull, Thomas Edison, and the Creation of the Modern Metropolis.** Palgrave Macmillan, 2006. 270 pp. \$24.95. Biography of Insull, Edison's protégé who rose to become a tycoon by electrifying the American Midwest. His complex financial maneuvers were as legendary as his downfall in the market crash of 1929. *Rev.: T&C*, Vol. 48, 1 (Jan. 2007), pp. 218-19.

## LUMBER & PAPER

- ◆ Monica Davey. **A Beetle and Balmy Weather May Bench a Baseball Staple.** *NY Times* (July 11, 2007). The Larimer & Norton lumber mill in Russell, Pa. provides the ash wood that is used to shape major league baseball bats. The emerald ash borer, an invasive beetle from Asia, is devastating white ash trees. Authorities have begun collecting seeds for storage in case the species is wiped out.
- ◆ Ted Genoways, ed. **Papermill: Poems, 1927-35, Joseph Kalar.** Univ. of Ill. Pr., 2006. 73 pp., \$30; \$14.95 paper. Collected poems of a laborer in the paper mills of International Falls, Minn. provide a portrait of the Depression. Introduction provides regional, literary, and historical contexts.
- ◆ William A. Lansing. **Seeing the Forest for the Trees.** 2005. History of the Menasha Forest Products Corp. in Coos Bay, Ore. **Can't You Hear the Whistle Blowin': Logs, Lignite, and Locomotives in Coos County, Oregon.** 2007. History of logging locomotives and the companies that ran them. Avail. [www.amazon.com](http://www.amazon.com). Author is the former CEO of Menasha Forest Products.
- ◆ Tod Milburn. **Lumbering to Uncertainty.** *Sacramento Bee* (Oct. 13, 2007). Scotia, Calif., founded in 1883, is Pacific Lumber's headquarters with about 275 employees. Water, sewer, and electricity are provided free of charge, but the future of the town is uncertain. Parent company, MAXXAM, Inc., is in bankruptcy.
- ◆ Ray Schreiner. **Tops in Blotters.** *FiftyPlus Magazine* (Richmond, Va., Nov. 2007). Brief history of the Albermarle Paper Co., also known as the Hollywood Mill, built in 1877 between the James River and the Kanawha Canal. Operated until 1962.

## MINES & MINING

- ◆ Alan Cockrell. **Drilling Ahead: The Quest for Oil in the Deep South, 1945-2005.** Univ. of Miss. Pr., 2005. 368 pp. \$35. Chronological, state-by-state account. Rev.: *T&C*, Vol. 48, 1 (Jan. 2007), pp. 203-4.

### CONTRIBUTORS TO THIS ISSUE

Richard K. Anderson, Jr., Sumter, SC; Sandy Carter, Marylhurst, OR; Robert Chidester, Ann Arbor, MI; Arlene Collins, Houghton, MI; Gil Cooke, West Yarmouth, MA; Reese Davis, West Chester, PA; Christopher J. Dawson, Cleveland, OH; Steven DeVore, Lincoln, NE; Don Durfee, Houghton, MI; Aarne Frobom, Hazlett, MI; Dennis Furbush, Jackson Heights, NY; Sarah Gaulty, Burlington, VT; Mary Habstritt, New York, NY; Julie Harris, Ottawa, ON; Neill Herring, Jesup, GA; Ken Lavelle, North Royalton, OH; Carol Lockman, Wilmington, DE; Dan McCain, Delphi, IN; Alicia H. Moore, Ipswich, MA; Cydney Millstein, Kansas City, MO; Roger Pellett, Duluth, MN; Dave Poirier, Hartford, CT; Lynn Rakos, Brooklyn, NY; Rick Rowlands, Youngstown, OH; Fred Schaeffer, Poughkeepsie, NY; Henry Schwinge, Evanston, IL; Mo Spaulding, Northfield, MA; Justin Spivey, New York, NY; Tyler Turpin, Richmond, VA; Robert M. Vogel, Washington, DC; Suzanne Wray, New York, NY.

*With Thanks.*

- ◆ Thomas Dublin and Walter Licht. **The Face of Decline: The Pennsylvania Anthracite Region in the Twentieth Century.** Cornell Univ. Pr., 2005. 275 pp., photos. \$24.95. An analysis of the economic, social, and environmental impacts. Rev.: *T&C*, Vol. 48, 1 (Jan. 2007), pp. 205-6.
- ◆ David A. Fahrenthold. **In Deserted Md. and W.Va. Towns of Coal Mining's Past, Historians Work to Save What's Left: Their Memory.** *Washington Post* (Oct. 3, 2007), p. B1. Collecting the history of coal patch towns, including interviews of former residents and videotapes of the town sites.
- ◆ Karen Bescherer Metheny. **From the Miners' Doublehouse: Archaeology and Landscape in a Pennsylvania Coal Company Town.** Univ. of Tenn. Pr., 2007. 376 pp., illus. \$45. A study of the town of Helvetia uses material culture to form a picture of how its occupants shaped spaces for specific activities, like gardening or sports competitions, or altering the company-built doublehouse to suit their own purposes. Rev.: *VAN* (Summer 2007), p. 18.
- ◆ Andrew E. Kramer. **For One Business, Polluted Clouds Have Silvery Linings.** *NY Times* (July 12, 2007). Norilsk in Siberia, Russia, where pollution from nickel smelters has killed over 1.2 million acres of forest. The price of nickel has risen so steeply that local businessmen dredge and bulldoze the sludge to recover nickel dust from the dead lakes and forests.
- ◆ Stephen Regenold. **Industrial Echoes in Michigan's Copper Country.** *NY Times* (Aug. 10, 2007). Travelogue of the Upper Peninsula, including many sites from the 1997 SIA Annual Conference.
- ◆ **Sunset on Sunrise: Boom and Bust in the Iron-Rich Hills of a High Desert Mining Town.** *Common Ground* (Winter 2007), pp. 8-11. Wyoming's Sunrise Mine, operated by the Colorado Fuel & Iron Co. from 1898 to 1980. Short history of 225-acre district recently listed on the National Register. Info: [www.cr.nps.gov/commonground](http://www.cr.nps.gov/commonground).

## IRON & STEEL

- ◆ Joseph Kahn and Mark Landler. **China Grabs West's Smoke-Spewing Factories.** *NY Times* (Dec. 21, 2007). The blast furnace at ThyssenKrupp's former steel mill in Germany's Ruhr valley was dismantled and shipped to Handan in China's "new" Ruhr valley. Compares the impact on German and Chinese communities.
- ◆ Heather Timmons and J. Adam Huggins. **New York Manhole Covers, Forged Barefoot in India.** *NY Times* (Nov. 26, 2007). Investigation and photos of work in foundries in West Bengal, which annually produce thousands of manhole covers for Con Edison and other U.S. utilities. There are few safety protections for workers who make a few dollars per day.

## TEXTILES

- ◆ Curtis J. Evans. **The Conquest of Labor: Daniel Pratt and Southern Industrialization.** La. State Univ. Pr., 2001. 337 pp. \$49.95. Pratt was among the first New Englanders to transfer cotton mill technology to the South in the 1830s. He used free and slave labor in his Georgia mills, and worked to promote the region's industrial development prior to the Civil War. Rev.: *T&C*, Vol. 45, 1 (Jan. 2004), pp. 190-91.
- ◆ Tamara Hareven. **Silk Weavers of Kyoto: Family and Work in a Changing Traditional Industry.** Univ. of Calif. Pr., 2003. 346 pp. \$21.95. Household-based weaving where generations of silk weavers have produced obi, or sash, worn over the kimono. Rev.: *T&C*, Vol. 45, 1 (Jan. 2004), pp. 177-78.

- ◆ Laura Thatcher Ulrich. **The Age of Homespun: Objects and Stories in the Creation of an American Myth.** Alfred A. Knopf, 2001. 501 pp. \$35. A narrative built around museum objects explains the transformation of textile making in New England from the 17th c. through the 19th c. The origins of an imagined era of “homespun” that was embraced to counter concerns about industrial mill cities. Rev.: *T&C*, Vol. 45, 1 (Jan. 2004), pp. 186-88.
- ◆ Katie Zezima. **Its Mill Days Gone (and Not Coming Back), a Small Town Tries Plans B and C.** *NY Times* (Sept. 2, 2007), p. K12. Berlin, N.H., struggles with high unemployment and a recent string of fires in abandoned textile mills. A familiar story; Berlin is pinning its economic hopes on a new prison and park for all-terrain vehicles.

## RAILROADS

- ◆ Ian J. Kerr. **Railways of India.** Oxford Univ. Pr., 2001. 356 pp. Essays explore the place of railways in the formation of modern India. Rev.: *T&C*, Vol. 45, 1 (Jan. 2004), pp. 180-81.
- ◆ Benjamin F. Kline, Jr. **Little, Old and Slow: The Life and Times of the Peach Bottom & Lancaster, Oxford & Southern Railroads.** 96 pp., photos, maps. \$15. (Avail. from Friends of the East Broad Top Co. Store; [febtstore@comcast.net](mailto:febtstore@comcast.net)). The 3-ft. gauge Peach Bottom Ry.'s eastern division, constructed in 1872-78, linked the east bank of the Susquehanna River to Oxford in rural Lancaster County, Pa. Hauling milk and agricultural products, the railroad was reorganized as the LO&S in 1890, which ceased operations in 1919.
- ◆ **Mid-Continent Railway Gazette** is the quarterly publication of the Mid-Continent Ry. Historical Society, North Freedom, Wis. Vol. 40, 3 (Oct. 2007) includes a report on activities at the railroad museum, details of machine work in restoring a steam locomotive (Western Coal & Coke #1), and a detailed report on the Temiscouata steam railway in New Brunswick and Quebec. Info: [www.midcontinent.org](http://www.midcontinent.org).
- ◆ Richard J. Orsi. **Sunset Limited: The Southern Pacific Railroad and the Development of the American West, 1850-1930.** Univ. of Calif. Pr., 2005. 615 pp. \$29.95. Based on years of research in corporate records, depicts the SP as exerting its well-known political and economic power, but also how many of its mid-level managers sought ways to support scientific agriculture, the promotion and creation of national parks, family farms, and conservation practices. Rev.: *T&C*, Vol. 48, 1 (Jan. 2007), pp. 213-14.
- ◆ **Railway Museum Quarterly** is the publication of the Assn. of Railway Museums. No. 45 (Fall 2007) includes articles on the positive impact of the federal transportation enhancement program on railway preservation, rebuilding the Maryland & Pennsylvania RR under the program, a very detailed report on restoring the trucks of a double-truck freight locomotive at the Seashore Trolley Museum, and a review of the Fort Smith (Ark.) Trolley Museum. Info: [www.railwaymuseums.org](http://www.railwaymuseums.org).
- ◆ John H. Roy, Jr. **A Field Guide to Southern New England Railroad Depots and Freight Houses.** Branch Line Pr. ([www.branchlinepress.com](http://www.branchlinepress.com)), 2007. 320 pp. Comprehensive guide to all 467 surviving structures. Each entry includes a photograph, year built, present use, and brief historical and architectural notes.
- ◆ Zachary M. Schrag. **The Great Society Subway: A History of the Washington Metro.** Johns Hopkins Univ. Pr., 2006. 384 pp. \$30. How the 105-mile-long subway system came about and its impact on the capital city. Rev.: *T&C*, Vol. 48, 1 (Jan. 2007), pp. 216-18.
- ◆ **Timber Transfer** is the quarterly publication of the Friends of the East Broad Top RR National Historic Landmark in Huntingdon Co., Pa. Vol. 23, 3 (Winter 2007) includes detailed drawings and photos of the sand house and a steel girder bridge, notes on restoring a mid-1920s speeder, and general news about the railroad. Avail. with membership, \$30/yr. Info: [www.febt.org](http://www.febt.org).

## AERONAUTICS & AEROSPACE

- ◆ Virginia P. Dawson and Mark D. Bowles, eds. **Realizing the Dream of Flight: Biographical Essays in Honor of the Centennial of Flight, 1903-2003.** NASA, 2005. 310 pp. \$20. Essays cover Bessie Coleman (the first African-American woman to earn a pilot's license); Amelia Earhart (famed aviatrix); Benjamin Davis, Jr. (first black officer in the U.S. Army Air Corps); Juane Trippe and Charles Lindbergh (their roles in developing Pan American World Airways); Eddie Rickenbacker and Johnny Miller (airmail service); Donald Douglas (founder of Douglas Aircraft); Robert Gilruth (first director of the Manned Space Center in Houston); Wernher von Braun (rocket science); Hugh Dryden (first deputy administrator of NASA); Willey Ley (popularization of space exploration); and Curtis LeMay (strategic airpower). Rev.: *T&C*, Vol. 48, 1 (Jan. 2007), pp. 232-34.
- ◆ Joe Flanagan. **Sputnik at 50: The Legacy of the Space Race.** *Common Ground* (Winter 2007), pp. 24-37. The National Park Service has conducted a theme study and surveys identifying historically significant launch sites and research facilities. Info: [www.cr.nps.gov/commonground](http://www.cr.nps.gov/commonground).
- ◆ Tom Huntington. **Racetracks in the Sky.** *I&T* (Spring 2007), pp. 42-51. Aerial contests of the 1920s and 1930s bred more competitive and technologically advanced aircraft.
- ◆ Stephen Joiner. **Better Flying Through Chemistry.** *I&T* (Spring 2007), pp. 17-19. Leo Windecker's experiments with plastic-bodied airplanes in the late 1950s to 1960s.

## AUTOMOBILES & HIGHWAYS

- ◆ Gabrielle Barnett. **Drive-By Viewing: Visual Consciousness and Forest Preservation in the Automobile Age.** *T&C*, Vol. 45, 1 (Jan. 2004), pp. 30-54. California Hwy. 101 (Redwood Hwy.) north of San Francisco was embraced by environmentalists in the 1920s for its appeal to tourists. Changes to the highway in the 1950s made it more suitable for logging trucks.
- ◆ L. Robert Puschendorf. **The “Bungalow” Filling Stations of the Standard Oil Company in Nebraska.** *SCA Journal* (Fall 2007), pp. 19-21. Scale drawing and advertising art.
- ◆ Frank E. Wrenick. **The Streamline Era Greyhound Terminal: The Architecture of W. S. Arrasmith.** McFarland & Co., 2007. 204 pp. \$49.95. Arrasmith designed more than 50 Greyhound bus terminals from 1937 to 1959. Includes brief history of Greyhound and its predecessor companies. Rev.: *SCA Journal* (Fall 2007), p. 34.

## BRIDGES

- ◆ **Bridge News** is the newsletter of the Historic Bridge Foundation. Summer 2007 features the Calhoun County (Mich.) Historic Bridge Park where five metal trusses have been restored and preserved. Info: [www.historicbridgefoundation.com](http://www.historicbridgefoundation.com).

- ◆ Frederic D. Schwarz. **Better Safe Than Sexy? What Happens When a 19th-Century Bridge Has to Meet 21st-Century Standards.** *I&T* (Spring 2007), p. 6. The Hadley (N.Y.) Bow Bridge, an 1885 lenticular truss (*SIAN*, Fall 2006).
- ◆ **SIA New England Chapters Newsletter**, Vol. 29, 2 (2007) includes three bridge-related articles: Amanda Ciampolillo, *FEMA Restoration of Silvermine Avenue Retaining Wall and Culvert, Norwalk, Conn.* (repairing a pre-1851 retaining wall with post-and-lintel culvert opening); Brian A. Sweeney, *Perry Avenue Bridge Improvements* (repairing an 1899 stone arch in Norwalk); and Stacy Vairo, *Devon Rail Bridge Gets a Lift* (history of 1905 Scherzer rolling lift bridge over the Housatonic River on the Northeast Corridor in Milford-Stratford, Conn.)

## BUILDINGS & STRUCTURES

- ◆ Bernd Brunner. **The Ocean at Home: An Illustrated History of the Aquarium.** Princeton Architectural Pr., 2005. The origins of aquariums in the 19th c. when workable technology was developed and aquariums enjoyed their first popularity. Rev.: *T&C*, Vol. 48, 1 (Jan. 2007), pp. 186-88.
- ◆ Charles W. Ebeling. **Revolutionary Restaurants.** *I&T* (Spring 2007), pp. 52-55. History and construction of revolving restaurants. The first opened in 1961 atop the Ala Moana building in Honolulu.
- ◆ Thomas T. Fettes. **The Lustron Home: The History of a Postwar Prefabricated Housing Experiment.** McFarland & Co., 2002. 186 pp. \$35. History of the Chicago-based Lustron Corp. that manufactured modular homes from porcelain enamel from about 1945 to 1950. The company was hampered by business problems and poor management. Rev.: *SCA Journal* (Fall 2007), p. 33.
- ◆ Rachel Maines. **Asbestos and Fire: The Technological Trade-Offs and the Body of Risk.** Rutgers Univ. Pr., 2005. 254 pp. \$34.95. History of asbestos from its rise as a wonderful building material that helped to decrease the risk of fires to its demise as a danger to human health. Rev.: *T&C*, Vol. 48, 1 (Jan. 2007), pp. 175-77.
- ◆ Henry Petroski. **Pushing the Limits: New Adventures in Engineering.** Alfred A. Knopf, 2004. 288 pp. \$25. An analysis of engineering structures that push or challenge conventional design, including the Britannia Bridge, London's Tower Bridge, the Millennium Wheel, the Guggenheim Art Museum, skyscrapers of Fazlur Khan, and the Three Gorges Dam. Rev.: *T&C*, Vol. 48, 1 (Jan. 2007), pp. 181-82.
- ◆ Mark Wolverton. **The DEW Line.** *I&T* (Spring 2007), pp. 32-41. Radar and communication stations that made up North America's Distant Early Warning Line above the Arctic Circle. Begun in 1952 to warn against Soviet attack.

## AGRICULTURE & FOOD PROCESSING

- ◆ **Harvest in the Barrens.** *Common Ground* (Winter/Spring 2007), pp. 8-11. National Park Service project to document the history and landscape of cranberry-growing enterprises in N.J.
- ◆ Douglas Cazaux Sackman. **Orange Empire: California and the Fruits of Eden.** Univ. of Calif. Pr., 2005. 386 pp. \$45. Development of the citrus belt with an emphasis on labor practices. Rev.: *T&C*, Vol. 48, 1 (Jan. 2007), pp. 215-16.

## GLASS

- ◆ Michael Lamm. **The Fiberglass Story.** *I&T* (Spring 2007), pp. 8-16. It started with a couple of lab mistakes, proved to be a breakthrough for filters and insulation, and soon was shaping the hottest cars and most creative furniture. Owens-Illinois Glass Co. in Alton, Ill.

- ◆ Timothy Messer-Kruse. **The Glass Boys of Ohio.** *Timeline*, Vol. 25, 1 (Jan.-Mar. 2008), pp. 20-37. Detailed look at child labor in Ohio's glass factories, ca. 1850-1920. Richly illustrated. As Ohio's glass industry boomed, a shortage of child labor stimulated technological changes such as conveyor systems. Avail: Ohio Historical Society, 1982 Velma Ave., Columbus, OH 43211. \$14 ppd.

## ARMS & AMMUNITION

- ◆ David Bachrach. **Crossbows for the King: The Crossbow during the Reigns of John and Henry III of England.** *T&C*, Vol. 45, 1 (Jan. 2004), pp. 102-119. The variety of materials employed in crossbow construction and the relative ratios of various crossbow types among the English troops, 1199-1272.
- ◆ C. L. Bragg, et. al. **Never for Want of Powder: The Confederate Powder Works in Augusta, Georgia.** Univ. of S.C. Press, 2007. illus. 318 pp. \$44.95. Definitive history of the establishment and successful operation of the powder works. Includes 70 plates of architectural drawings and photos. The works survived the Civil War only to be torn down in the 1880s, all except for the smokestack, to provide brick for textile mills. Rev.: *H-Southern-Industry* (Dec. 2007).

## MISC. INDUSTRIES

- ◆ Marc Olivier. **George Eastman's Modern Stone-Age Family: Snapshot Photography and the Brownie.** *T&C*, Vol. 48, 1 (Jan. 2007), pp. 1-19. The Eastman-Kodak advertising campaign for its classic "Brownie" camera, introduced in 1900.
- ◆ Bob Piwarzyk. **Lime Kiln Legacies.** 2007. Avail: Museum of Art & History, Santa Cruz, Calif. (<http://limekilnlegacies.com/order.php>). Documents the lime industry in Santa Cruz Co. from 1791 to 1946, including a detailed guide to the ruins of an operation at the entrance of UC-Santa Cruz. Rev.: *Samuel Knight Chapter SIA Newsletter*, No. 24 (Aug. 2007), p. 7.
- ◆ Mike Toner. **Frontier-Era Discovery Unearths Raw History.** *Atlanta Journal-Constitution* (Nov. 12, 2006). Archeologists have been investigating the site of the ca. 1811-64 Clinton Tannery near Macon, Ga. Remains of seven wood-lined vats and a bark mill have been found.

## ABBREVIATIONS:

<i>I&amp;T</i>	= <i>American Heritage of Invention &amp; Technology</i>
<i>IA News</i>	= published by the Assn. for Industrial Archaeology (U.K.)
<i>SCA</i>	= Society for Commercial Archeology
<i>T&amp;C</i>	= <i>Technology &amp; Culture</i> , published by the Society for the History of Technology (SHOT)
<i>TICCIH</i>	= The International Committee for the Conservation of the Industrial Heritage
<i>VAN</i>	= <i>Vernacular Architecture Newsletter</i> , published by the VA Forum ( <a href="http://www.vernaculararchitectureforum.org">www.vernaculararchitectureforum.org</a> ).

**Publications of Interest** is compiled from books and articles brought to our attention by you, the reader. SIA members are encouraged to send citations of new and recent books and articles, especially those in their own areas of interest and those obscure titles that may not be known to other SIA members. *Publications of Interest*, c/o *SIA Newsletter*, 305 Rodman Road, Wilmington, DE 19809; [phsianews@aol.com](mailto:phsianews@aol.com).



## GENERAL TOOLS AWARD

### *Nominations Due by April 16*

The General Tools Award Committee invites and encourages SIA members to submit nominations for the **2008 Society for Industrial Archeology General Tools Award for Distinguished Service to Industrial Archeology**.

The General Tools Award is the highest honor the SIA can bestow. The award recognizes individuals who have given sustained, distinguished service to the cause of industrial archeology and is presented at the SIA's annual business meeting.

Criteria for selection are as follows: (1) The recipient must have given noteworthy, beyond-the-call-of-duty service, over an extended period of time, to the cause of industrial archeology. (2) The type of service for which the recipient is recognized is unspecified, but *must be for other than academic publication*. (3) It is desirable but not required that the recipient be, or previously have been, a member of the SIA. (4) The award may be made only to living individuals. Teams, groups, agencies, firms, or any other collective entities are not eligible.

The nomination, which should not exceed three double-spaced typed pages, should address the specific accomplish-

ments that qualify the nominee for the award. Supplementary material (the candidate's resume, for example) may be appended to the nomination. Nominations must also include the name, address, telephone number(s), and e-mail of the nominator. Any SIA member in good standing may make a nomination.

The General Tools Award was established in 1992 through the generosity of Gerald Weinstein [SIA], chairman of the board of General Tools Manufacturing, Inc. of New York City, and the Abraham and Lillian Rosenberg Foundation. The Rosenbergs founded General Hardware, the predecessor to General Tools. The award consists of a citation, a commissioned sculpture ("The Plumb Bob"), and a cash award. Previous recipients are Emory Kemp (1993), Robert Vogel (1994), Edward Rutsch (1995), Patrick Malone (1996), Margot Gayle (1997), Helena Wright (1998), Vance Packard (1999), Eric DeLony (2000), Robert Merriam (2001), Charles Parrott (2002), Alex Barbour (2003), Charles Hyde (2004), Lance Metz (2005), and Patrick Martin (2007). There was no award in 2006.

Nominations, *which must be received on or before April 16, 2008*, should be submitted to:

Julie Harris, Contentworks Inc., 137 Second Ave., Ste. 1, Ottawa, ON K1S 2H4 CANADA; [jharris@contentworks.ca](mailto:jharris@contentworks.ca); (613) 730-4059; fax 730-4054. A USA mailing address can be

## SIA Slate of Candidates—2008

The Nominations Committee is pleased to present the following slate of candidates for the 2008 election:

### **President**

(2-year term)

*You will vote for one*

Mary Habstritt

### **Vice-President**

(2-year term)

*You will vote for one*

James Bouchard  
Jay McCauley

### **Director**

(3-year term)

*You will vote for three*

Scott Baxter  
Perry Green  
Amanda Gronhovid  
Mike Hamilton  
Tim Mancl

### **Nominations Committee**

(3-year term)

*You will vote for one*

Erin Timms  
Bill Vermes

SIA by-laws state that the Nominations Committee shall notify the membership of the proposed slate at least 70 days in advance of the Annual Business Meeting. **This is that notice; it is not a ballot.** Additional nominations may be made in writing over the signatures of no fewer than 12 members in good standing (dues paid for the 2008 calendar year) and delivered to the Nominations Committee chair at the address below no later than **April 21, 2008**. Candidates must have given their consent to be nominated and must also be members in good standing. Ballots, which will include a biographical sketch and photograph of each candidate, will be mailed in late April. Members must have paid their dues for the 2008 calendar year in order to vote.

The current Nominations Committee includes Cydney Millstein, Ed Grusheski, Christopher Marston and Chris Andreae, (*ex officio*). Please direct all nominations and other correspondence to: SIA Nominations Committee, c/o Cydney Millstein, 1537 Bellevue Ave., Kansas City, MO, 64108; (816) 472-4154; [Cydney@ahr-kc.com](mailto:Cydney@ahr-kc.com). ■

## IA EXHIBITS

The **Museum of Our Industrial Heritage** has found a new home in the former Greenfield (Mass.) Steel Stamp factory, which will be rehabilitated to hold the collection of cutlery, hand tools, machine tools, taps & dies, paper, textiles and numerous other products of Franklin County industries. Appropriately, the site has been occupied by industry in one form or another since 1689, including grist and saw mills, a foundry, and a machine shop. The current building dates to the 1820s with an 1870s addition. Info: [www.industrialhistory.org](http://www.industrialhistory.org).—*Mo Spaulding*

**Building America's Canals**, an exhibit funded by the National Science Foundation, will be touring in 2008-09. It was developed by the National Canal Museum (Easton, Pa.) and previously occupied the museum's Engineering America Gallery. Stops for the exhibit are the Discovery Center at Murfree Spring, Murfreesboro, Tenn. (Jan. 17-Apr. 10, 2008); C&O Canal National Historic Park, Williamsport, Md. (Apr. 17-Oct. 10, 2008); Western Reserve Historical Society, Cleveland, Ohio (Oct. 17-Jan. 10, 2009); and the Mid-Hudson Children's Museum, Poughkeepsie, N.Y. (Jan. 17-Oct. 8, 2009).

**Build It!** will be the new exhibit opening in Mar. 2008 at the **National Canal Museum**. The exhibit will occupy the museum's entire fourth floor at Two Rivers Landing in Easton, Pa. It features interactive stations that enable visitors to experiment with building methods and materials. They can construct a house with Lincoln logs; create a "steel" structure with straws and connectors; build a wall with giant plastic bricks; and construct stone arches with Kappla Blocks. Historic structures highlighted include Chicago's Home Insurance Building, New York's Empire State Building, San Francisco's Golden Gate Bridge, Philadelphia's City Hall, and the Hoover Dam.

The State of North Carolina has stepped in to take over the **Graveyard of the Atlantic Museum** on Hatteras Island. The museum, which opened in 2002, features a collection of about 2,000 artifacts, many recovered from shipwrecks along this historically treacherous stretch of coast. It is located in a new building near the state ferry docks, but has struggled financially despite attracting over 50,000 visitors annually. The museum currently has exhibits on the Cape Hatteras Lighthouse's original lens, the radio shack where Billy Mitchell worked to prove that airplanes could sink battleships, and a coding machine retrieved from a German submarine that sank off the coast. The N.C. Dept. of Cultural Resources is assessing the museum and its collection to determine staffing and how to complete the exhibits.—*Raleigh News-Observer (Sept. 19, 2007)*

**Palazzos of Power: The Generating Stations of the Philadelphia Electric Co., 1900-1930** is an exhibit running at the Athenaeum of Philadelphia through March 21.

The exhibit features photographs by Joseph Elliott (SIA) for the Historic American Buildings Survey/Historic American Engineering Record (HABS/HAER), as well as archival images. Designed by architect John Torrey Windrim and engineer William Charles Lawson Eglin, PECO's power stations on the banks of the Schuylkill and Delaware rivers employed an architectural vocabulary that simultaneously evoked Beaux Arts tradition and cutting-edge modernity. The exhibit is open 9-5, M-F. Admission free. Info: (215) 925-2688.

The **Old Barracks Museum** (Trenton, N.J.) is hosting an exhibit on the industries of Revolutionary War-era Trenton as told through historic research and archeological studies of one man's varied businesses. *Remarkable for His Industry: William Richards, Trade & Manufacture in Revolutionary Trenton* provides a glimpse of how this "middling" businessman ran his works, which included a commercial fishery, stoneware pottery, cooperage, bakery, large store, and a schooner. On view until July 2008. Info: [www.barracks.org/activities/remarkable.html](http://www.barracks.org/activities/remarkable.html).

The **historic tugboat Huntington** has been relocated from the National Maritime Center (NMC) in Norfolk, Va. to the Palm Beach (Fla.) Maritime Museum. The 109-ft.-long tug was launched in 1933 and worked the waters off Newport News until being retired in 1992. The NMC transferred the tug to Florida to make room for other exhibits. Named after Collis P. Huntington, founder of the Newport News shipyard, the tug is open to the public and will serve as a floating classroom for the Palm Beach Maritime Academy.—*Palm Beach Post (Jun 13, 2007)*

The **Railroad Museum of Pennsylvania** (Strasburg), as part of its annual giving campaign, is raising funds to restore the Pennsylvania RR E6s Atlantic locomotive No. 460, also known as the Lindbergh Engine for its role in speedily delivering newsreels of President Calvin Coolidge awarding aviator Charles Lindbergh a presidential medal of honor in 1927. No. 460 was built in 1914 and retired in 1955. To learn more: [www.rrmuseumpa.org](http://www.rrmuseumpa.org). ■





## Port of Richmond's Diesel Locomotives Preserved

The Port of Richmond is located on the James River, 100 miles from Cape Henry and approximately 78 miles above Newport News, Va. It is the western terminus for commercial navigation on the James. The present-day port began in 1938 with most of the construction paid for by the federal Public Works Administration, but since its founding it has been owned by the City of Richmond, managed by the Port of Richmond Commission, and operated by a private company through a lease agreement. Several original warehouses and support buildings are still in use and can be seen from I-95.

The port's railway used diesel locomotives from its beginning. The port maintained 7.5 miles of track (since reduced in length) that ran up to the dock and interchanged at the port perimeter. The port ordered two locomotives from Davenport (one a 25-ton rear cab delivered in 1938, the other a 44-ton center cab delivered in 1939). These remained the only locomotives at the port until the mid-1990s. The 1938 Davenport is believed to be the first diesel assigned to a Virginia address. Both locomotives are preserved. The Walkersville Southern, a tourist railroad in Maryland, now operates the 25-ton rear cab. The Old Dominion Chapter of the National Railway Historical Society owns the 44-ton center cab. It is stored at the chapter's yard in Chesterfield County with work progressing on restoring it to operation.

To learn more about the locomotives and the port:

- [www.wsr.org/roster.htm](http://www.wsr.org/roster.htm) (Walkersville Southern RR/1938 Davenport)

- <http://odcnrhs.org/docs/ch-equipment.asp> (Old Dominion Chapter NRHS/1939 Davenport)
- <http://southern.railfan.net/ties/1960/60-10/rich.html> (Photos of the port in 1960)
- [www.richmondgov.com/departments/PortofRichmond/](http://www.richmondgov.com/departments/PortofRichmond/) (Modern port operations and photos)

Tyler Turpin



Courtesy Walkersville Southern web site.

*The 25-ton Davenport locomotive, in use at the Port of Richmond from 1938 to the mid-1990s, is now preserved by the Walkersville Southern.*



*The Port of Richmond. From Ties (Southern Ry. magazine), Oct. 1960.*

## SITES & STRUCTURES

### Saved

The **Edenton (N.C.) Peanut Mill**, built in 1909, has been rehabilitated with federal historic rehabilitation tax credits. More than \$2 million in work has converted the building to a first-floor fitness center and second-floor offices. The surviving peanut processing machinery was cleaned and has been preserved in place. The open floor plan was retained, using partial-height partitions and glazed walls to reveal the heavy timber framing and masonry walls.—*NPS Heritage News* (Dec. 2007)

The **Domino Sugar Refinery** (tour site—1995 SIA Annual Conference, Baltimore) suffered an explosion and fire in November. Dust from the confectioner's sugar line ignited, causing more than \$2 million in damage. The multi-story plant, which opened in 1920, is a Baltimore harbor landmark with its great neon sign, "Domino Sugar." Shortly after the explosion, the sign was re-lit as a symbol that all would be well. The refinery resumed operations one week after the fire.

Local preservation groups are taking an interest in **U.S. Forest Service fire towers** in the Southeast. Volunteers are working with the Sumter National Forest in Edgefield County, S.C., to maintain a galvanized-steel tower manufactured by Aermotor of Chicago in 1935. Another group is raising \$100,000 to rehabilitate the 40-ft.-tall Pinnacle Mountain Fire Tower, built in 1931 in the Cherokee National Forest near Unicoi, Tenn. Plans are to open the tower, which has been closed since 1989, as an observation platform. Most of the towers, which came in various sizes and styles, have been decommissioned because airplanes have taken their place.—*Augusta (GA) Chronicle* (Dec. 17, 2007) & *Knox News Sentinel* (Nov. 5, 2007)

The **Ottawa Street Power Station** in Lansing, Mich., is getting a new lease on life. Built in 1939 by the Board of Power & Light, the Art Deco-style power station is an architectural gem. It closed in 1992, and there has been controversy over what to do with it. A combination of tax credits and redevelopment grants now will help the Accident Fund Insurance Co. to convert the building into office space. Extensive coverage and a history of the station are in *The Lansing City Pulse* (Oct. 10-16, 2007); [www.lansingcity-pulse.com](http://www.lansingcity-pulse.com)

The **National Iron & Steel Heritage Museum** at Lukens Steel in Coatesville, Pa. (tour site—2005 SIA Fall Tour, Wilmington) has acquired a **sonarsphere**, a mammoth, dimpled steel ball, weighing 27 tons and designed for use on nuclear submarines. It contains over 1,200 hydrophones for the sonar system. The sonarsphere was acquired as surplus from the Portsmouth Naval Shipyard in Kittery, Maine. It was manufactured at Lukens in 1984.

The City of Albuquerque, N.M. has authorized the purchase of the former **Santa Fe locomotive shops** for \$9 million. The shops have about 25 buildings, some of which will house the Wheels Museum on the history of transportation. A portion of the site will be converted to affordable housing. The shops were established in 1915 and remained vital until the switchover from steam to diesel in the 1950s. They were later used as a track repair facility but were closed in the 1980s.

### Threatened

State officials closed **Empire-Fulton Ferry State Park** (tour site—2002 SIA Annual Conference, Brooklyn) in December following reports that the **Empire Stores**, a significant tea and coffee warehouse dating to the 1860s, was structurally unsafe. Plans to develop the Empire Stores as an arts venue or commercial space have been allowed to languish since the 1980s. A succession of developers have held the development rights but failed to act.—*Brooklyn Paper* (Dec. 29, 2007)

The City of New York has taken back **Pier A** from a private developer who failed to follow through on plans to preserve and re-open it as a gateway to ferries to the Statue of Liberty, Ellis Island, Governors Island, and Brooklyn. Pier A is a Victorian structure built in 1886 and located at the northern edge of Battery Park in lower Manhattan. The city plans to negotiate with the National Park Service to use the pier for passenger screening and boarding ferries.—*NY Times* (Aug. 7, 2007)

**Kodak Park** in Rochester, N.Y., was, at 1,600 acres, once the largest industrial complex in the Northeast. Now, however, the factories where film, paper, and chemical products were made are disappearing fast with the growth of digital photography. In the past four years the park has been reduced to 700 acres, and in the last year alone three major factories were imploded, including Building 50, a four-story paper products plant built in 1918.—*Wall Street Journal* (Oct. 3, 2007)

A battle is being waged over the future of the historic **Union Pacific Shops** (tour site—1996 SIA Annual Conference, Sacramento). The dispute is over seven historic buildings, including the erecting shop, portions of which date to 1868 and the establishment of the transcontinental railroad. The Union Pacific allowed the California State RR Museum to store and restore cars and locomotives in the shop, and there was an understanding that the museum would eventually receive it as an expansion to the adjacent museum in Old Sacramento. The museum even paid to have the 65-ton transfer table restored. But since the railyard was bought last year by Thomas Enterprises, a Georgia-based developer, plans have become unsettled. Thomas has

stated that it is not willing to part with the buildings and that this was never part of the agreement. City and state officials are lining up to support the museum.—*Sacramento Bee* (Oct. 20, 2007)

**National Vulcanized Fibre** in Yorklyn, Del. (tour site—2005 SIA Fall Tour, Wilmington) remains shut down. The plant, which retains much of its late-19th-century machinery for making the strong board of wood pulp, cotton, and zinc chloride, closed in 2003 due to flooding. The market for vulcanized fibre had been declining for decades. By 2003, NVF's workforce had shrunk from a high of 1,800 workers to 30. In recent years, NVF has been known less as a manufacturer and more as the corporate shell through which financier Victor Posner leveraged the buy-out of other companies. Local investors have taken the Posner interests to court in an attempt to release NVF from debt and promote activities that would re-invigorate the Yorklyn plant. The business plan would include using the facilities to manufacture Yorkite Veneer, a vulcanized wood laminate that has the feel and sustainability of real wood.—*Wilmington News-Journal* (Nov. 11, 2007)

Chicago's city council has passed an ordinance to stay the demolition of **wooden water tanks**. The gravity-fed rooftop water tanks are rapidly disappearing; in the past ten years more than half of the tanks have been destroyed, with only 178 remaining in service. The tanks proliferated in the years following the Great Fire of 1871, but began to be replaced in the 1950s by other types of fire suppression systems. The tanks are typically made of redwood, which lasts 40 to 50 years. Johnson & Carlson is the last Chicago firm to specialize in tank reconstruction and repair.—*www.preservationonline.org* (Nov. 16, 2007)

## Lost

The **Jack Wade Dredge**, a 1906-07 gold dredge, has been demolished by the federal Bureau of Land Management (BLM). One of the first bucket-line steam dredges to work Alaska's Fortymile mining district, the Jack Wade Dredge was shut down and abandoned in 1941. It became a familiar landmark at milepost 86 on the 160-mile-long Taylor Highway (Tok to Eagle) and a favorite spot for locals and tourists alike to stop and explore. The BLM, however, determined that it was unsafe and after a fence failed to deter visitors, the decision was made to demolish it. Several large pieces of the dredge—boiler, gearing, winching machinery, trammel, and buckets—were saved and will be put on display near the post office in Chicken, a small mining town a few miles south.—*Fairbanks Daily News-Miner* (Oct. 15, 2007)

## And Found

The drought in the Southeast has been lowering the water level in rivers and reservoirs, in the process uncovering a number of IA finds. A rare wooden river boat, about 80-ft. long and likely dating to the 1820s, has been uncovered in the Tar River near Tarboro, N.C. State officials are researching the boat and asking the public to refrain from disturbing it. And in Georgia's Vernon River near Savannah, archeologists have located the remains of the *USS Water Witch*, a 160-ft.-long steamship built in 1851 and seized by Confederates in 1864. It was scuttled after being stripped of its armaments, but it is believed that most of the steam engine remains along with a variety of other ship's artifacts. In the Great Smoky Mountains, park officials have found a 250-lb. forge hammer in Forge Creek. It is believed to have been part of the Cades Cove forge that made farm tools and implements in the 19th century.—*Knox News* (Nov. 20, 2007) & *Savannah Ledger-Enquirer* (Nov. 25, 2007) ■



*Jack Wade Dredge.*

HAER AK-19, Jet Lowe

## HISTORIC BRIDGE NEWS

The **10th Street Bridge** in Great Falls, Mont., a reinforced-concrete, open-spandrel arch bridge built in 1919-21, is sporting a new look. Final adjustments were made in early December to illuminate the bridge at night. The design is by Florida lighting expert Bob Daniels. The bridge was under threat of demolition in 1996 when local preservationists organized to save the bridge. With support from several SIA members, they were able to persuade the state to undertake a rehabilitation project (*SIAN*, Summer 1996 & Fall 1999). Preservation Cascade will pay to illuminate the bridge on holidays and weekends.—*Great Falls Tribune* (Nov. 29, 2007)

Efforts to preserve the **Poughkeepsie-Highland Bridge** (*SIAN*, Summer 2006) are progressing with the preservation group Walkway Over the Hudson recently receiving a \$500,000 grant from the State of N.Y. to convert the abandoned railroad bridge into a public walkway. The cantilever truss bridge was built in 1888 by the Union Bridge Co. as the first rail crossing of the Hudson below Albany. It was a significant milestone in cantilever truss construction with maximum span lengths of 548 ft. and an overall length of 6,768 ft. After a 1974 fire, the bridge was abandoned. Volunteers have been working to save it for more than a decade with the goal of opening it in time for the Hudson-Fulton-Champlain 400th anniversary in 2009.—*Fred Schaeffer*

The **Indiana Historic SPANS Task Force** received a National Preservation Honor Award from the National Trust for Historic Preservation in October. The task force is a 20-member group of representatives of the Indiana Historic Landmarks Foundation, Federal Highway Admin., Indiana Dept. of Transportation, and preservation professionals. It has worked successfully to resolve conflicting interests in the preservation of Indiana's historic bridges, developing a protocol and programmatic agreement that identifies bridges to be preserved through rehabilitation and continued use.—*Carroll County (IN) Comet* (Oct. 10, 2007)

A rare **Stearns truss bridge** has been restored by a group of volunteers from the Canal Center in Delphi, Ind. The 78-ft.-long, wrought-iron, through-truss bridge is an example of the 1890 patent of W. E. Stearns of Kansas. It was built by the Winamac Bridge Co. The main features of the patent were to elongate the panels and eliminate alternate verticals to save material as compared to a Pratt truss of similar length and design load. The volunteers purchased the truss for \$10 from the Pulaski County Commission in 2005. It was moved from its original location at Winamac to a new location in the Canal Park over the Wabash & Erie Canal. Over the course of the past two years, 76 volunteers assisted with the restoration project. More than 200 people attended the dedication celebrations in November. ■



Delphi Canal Center

*The Delphi (Ind.) Canal Center celebrated the restoration of the Stearns truss bridge. A 1903 Winton crosses the bridge.*

## IA IN ART

The **Man at Work Museum** at the Milwaukee School of Engineering (reception site—2005 SIA Annual Conference) has been in the news and a subject of controversy due to some of the paintings' connections to fascist Germany. The collection of more than 700 paintings and sculptures depicts scenes of work and industrial landscapes from the 16th century to the present. Eckart G. Grohmann collected the works and donated them to the school. The most-represented artist is Erich Mercker (1891-1973), who, as it turns out, was commissioned by Adolph Hitler to create images of the Third Reich's industry and infrastructure. Some holocaust-remembrance groups are urging the muse-

um to turn over any records it has about the previous owners of Mercker's work, which so far it has been reluctant to do. Some historians believe that interpretation of the pieces should explicitly explain their Nazi past rather than displaying them in the context of the historical evolution of work as Grohmann intended.—*Milwaukee Journal Sentinel* (Oct. 27, 2007)

The Willamette Falls (Ore.) Heritage Foundation recently organized an exhibit of contemporary art depicting the 1895 **T. W. Sullivan Hydroelectric Plant**. Through a remarkable

*(continued on page 22)*

## Tod Engine Reaches Milestone

The Tod Engine Foundation, owner of a 1914 William Tod Co. 34-in. x 68-in. x 60-in. cross-compound rolling-mill engine (tour site—2006 SIA Fall Tour, Youngstown, Ohio), has reached a major milestone in its attempt to restore and display the engine.

In 2007, the foundation made plans to construct a 4,000-sq.-ft. prefabricated steel building to house the engine and related exhibits. The building will resemble a typical Youngstown district mill building, complete with clerestory and corrugated-steel siding. A capital campaign was initiated with a two-year goal of raising \$40,000. As of the end of December, half of that goal has been raised, culminating with the receipt of \$5,000 from the William B. Pollock Foundation. The money will permit the foundation to place the order for the structural steel. Once springtime rolls around, volunteers will begin to excavate for footers and start pouring concrete. The use of outside contractors is being kept to a minimum to reduce costs.

The foundation has also just acquired an historic overhead crane for the museum. It was fabricated in 1892 by the Morgan Engineering Co. for the Otis Steel works in Cleveland.

Info and donations: Rick Rowlands, Tod Engine Foundation, 2261 Hubbard Rd., Youngstown, OH 44505; (330) 272-4089; [www.todengine.org](http://www.todengine.org). ■



*The 1914 Tod Engine. A building will soon surround the massive rolling mill engine that was rescued from the Brier Hill Steel Works in 1995.*

## IA ON THE WEB

**Augusta Canal National Heritage Area** ([www.nps.gov/nr/travel/Augusta/index.html](http://www.nps.gov/nr/travel/Augusta/index.html)). For tourists to learn about Augusta, Ga., and plan an itinerary including the canal, textile mills, and other industrial heritage sites.

**Domino Sugar Refinery** ([http://www.youtube.com/watch?v=cXX\\_PrJ61yY](http://www.youtube.com/watch?v=cXX_PrJ61yY)). 10-min. video by The Real Deal, a NYC real estate tabloid, covers plans for re-developing the Brooklyn refinery (tour site—2002 SIA Annual Conference). Features photos by SIA members Charles Kramer, Thomas Flagg, and Nathan Kensinger and interview with Mary Habstritt.

**Down the Drain: Chicago's Sewers** ([www.chipublib.org/digital/sewers/sewers.html](http://www.chipublib.org/digital/sewers/sewers.html)). Extensive history, gallery of photos, and virtual tours, including "Sewer-Cam" of Chicago's drainage systems. Draining the low-lying city has been an on-going technological challenge.

**London Transport** ([www.subways.net/uk/London.htm](http://www.subways.net/uk/London.htm)). Extensive contemporary and historical information on London's subways and light-rail systems.

**Military Archeology Listserve.** *Militarch* is an e-mail dis-

cussion list on military archeology, broadly defined to include anything that involves the documentation, interpretation, analysis, or management of military sites anywhere in the world. Contributions are welcome from multiple perspectives, including professional and amateur. To subscribe, send an e-mail to: [jiscmail@jiscmail.ac.uk](mailto:jiscmail@jiscmail.ac.uk).

**On This Very Spot** ([www.ontthisveryspot.com](http://www.ontthisveryspot.com)), sponsored by the American Assn. for State & Local History, is billed as "the world's first comprehensive travel guide to historical places throughout America and the world." History organizations are welcome to add their info to the database.

**Steel Heritage** ([www.steelheritage.org](http://www.steelheritage.org)) is a project of the Tod Engine Foundation to create a central clearinghouse of information related to iron and steel industry preservation in North America. At the present, the site consists of several discussion forums. It will expand to include links to steel-related organizations, an online inventory of extant iron and steel artifacts and sites, and other resources.

"IA on the Web" is compiled from sites brought to the editor's attention by members, who are encouraged to submit their IA Web finds: [phsianews@aol.com](mailto:phsianews@aol.com). ■

## CONFERENCES & WORKSHOPS

**TICCIH 2008.** The International Committee for the Conservation of the Industrial Heritage (TICCIH) will be holding the **First Chinese International Conference on Industrial Heritage** in Chengdu, P.R. China, Sept. 1-4, 2008. This event marks the growing willingness of China to engage with TICCIH. In 2006, China first attended and spoke at the TICCIH Congress in Italy. In 2007, the first paper on industrial heritage in China was published in the TICCIH journal, *Industrial Patrimony*, and in 2008, the first TICCIH conference will be held in China. Chengdu is the capital of Sichuan Province. The province includes the ancient Dujiangyan Irrigation System, which has been designated the first industrial World Heritage Site in China. There are also several industrial museums on the itinerary, including the Museum of Industrial Civilization, Museum of Printing, Museum of Traditional Paper Making, and Museum of Shu Brocade. Tours of active industries are also planned. Info: [www.ticcih.org](http://www.ticcih.org).

**International Committee for the History of Technology's 35th Annual Symposium** will be held in Victoria, B.C., Aug. 5-10, 2008. The primary theme is the examination of how technology influences and is influenced by the interaction of various types of boundaries. These boundaries are broadly defined to include the interaction among disciplines, theory, practice, scholarly schools, trades and professions, geographical areas, periods of time, cultures, political systems, ethnic groups, and nations. Features of the symposium include the annual Mel Kranzberg lecture by a distinguished historian of technology, the annual jazz night banquet, receptions, plenary session on Victorian technology and colonialism, excursions to the B.C. Forestry Discovery Centre, and whale watching. Info: <http://icohtec.uvic.ca/>.

**Automobility: A Conference on the 100th Anniversary of the Model T** will be held at the Hagley Museum & Library, Wilmington, Del., Nov. 6-7, 2008. Paper proposals are requested. The appearance of the Model T in 1908 ushered in a century during which motorized vehicles spread across the American landscape. Their impact was immense, visible in structures such as roads, bridges, garages and parking lots, in businesses including service stations and fast food restaurants, and in altered residential patterns. In addition to cars, other conveyances—such as buses, trucks, mobile homes, fire engines, and motorcycles, as well as vehicles produced for construction and military purposes—reshaped business and commerce, created new industries, and generated technological innovations. Hagley invites papers that reflect broadly the impact of

motor vehicles in America since 1908. As the automobile has been the subject of considerable scholarly work, papers concerning passenger cars should break new ground and address heretofore unexplored questions. Scholarship on other vehicles powered by internal combustion engines is far less developed and papers on their business, technological, and commercial dimensions are encouraged. Papers should be empirically based and historically informed. Proposals should be no more than 500 words and accompanied by a short cv. Deadline: Mar. 31. Travel support is available for presenters. Info: Carol Lockman, HML, Box 3630, Wilmington, DE 19807; (302) 658-2400, ext. 243; [clockman@hagley.org](mailto:clockman@hagley.org).

**National Park Service's Archeological Prospection Workshop**, Fargo, N.D., May 19-23, 2008, will be on the topic of current advances for non-destructive investigations. Field exercises will take place at the Biesterfeldt Site, a protohistoric village on the Sheyenne River. This will be the 18th year of the workshop dedicated to the use of geophysical, aerial photography, and other remote-sensing methods as they apply to the identification, evaluation, conservation, and protection of archeological sites across the nation. The workshop will present lectures on theory and operation, methodology, processing, and interpretation with hands-on use of equipment. This year's workshop has a special focus on soil magnetism and the effects of plowing on site integrity. Tuition is \$475. Applications and info: [www.cr.nps.gov/mwac/](http://www.cr.nps.gov/mwac/) or Steven L. DeVore, NPS, Midwest Archeological Center, Federal Bldg., Rm. 474, 100 Centennial Mall North, Lincoln, NE 68508; (402) 437-5392; [steve\\_de\\_vore@nps.gov](mailto:steve_de_vore@nps.gov). ■

---

## IA IN ART

(continued from page 20)

collaboration with Portland General Electric, artists were given the opportunity to explore the powerhouse in May 2007. The eight artists then produced paintings, photographs, and drawings inspired by their visit. The finished work went on display at the West Linn Library and has since moved on to a gallery in nearby Milwaukie. A handsome catalogue, *Art Contemplates Industry*, features an introductory essay by Betsy Fahlman [SIA]. Info: Sandy Carter, WFHF, Box 311, Marylhurst, OR 97036; (503) 650-9570. ■

## NOTES & QUERIES

Good news for researchers: the *NY Times* has announced it will stop charging for access to most parts of its Web site. Archived articles from 1851 to 1922 and 1987 to the present will be free to all readers. There will still be charges for some material from 1923 to 1986, but not all. Info: [www.nytimes.org](http://www.nytimes.org).

**Library of Congress Launches National Newspaper Database.** This database, under development, has gone online with approximately 310,000 newspaper pages, dating from 1900 to 1910. The coverage is somewhat limited as yet with more decades and newspapers to be added, but the library is constantly adding new data. Info: [www.loc.gov](http://www.loc.gov), click on Chronicling America.

**IA in Numismatics.** The U.S. Mint released the *Crossroads of the West* commemorative quarter in Salt Lake City on Nov. 9. The coin features the locomotives *Jupiter* and *No.*

119 facing the golden spike that joined the tracks of the transcontinental railroad in 1869.—*NPS Heritage News* (Dec. 2007)

**IA in Philately.** Canada Post has issued five stamps depicting historic lighthouses: the 110-ft.-tall imperial light built in 1855-59 at Pt. Clark, Ont.; the light at Pachena Pt., B.C.; the 1908 light at Warren Landing, Man.; the light at Gaspé Peninsula, marking the entrance to Forillon National Park, P.Q.; and the 1758 light on Sambo Island, N.S.

The Minnesota Historical Society has acquired the **Richard Ferrell Flour Milling Industry History Collection**. Assembled by retired miller Richard Ferrell, the collection contains some 5,000 items, including cookbooks, broadsides, trade journals, flour sacks, company letterheads, and photographs documenting every era of the flour milling industry. ■

---

### **AUTOMATIC BLOCK SYSTEM** (continued from page 9)

ways. It, like the color-light signal, eliminated the moving parts and dual aspect nature of semaphores. In addition, the uncolored lights were said to better penetrate fog and remove any risk of a color-blind engineman misinterpreting an aspect. Additionally, it possessed a built-in safety provision in the event of light failure: if two lights were extinguished on the bottom row, either diagonal or vertical, with the top row horizontal, the signal displayed the “stop and proceed” aspect; if all lights failed in these rows, the indication was “stop.” “In general,” explained the *Railway Age Gazette*, “the more lights extinguished, the more restrictive the indication.” Despite their benefits, the position-light signal’s high maintenance costs and rejection of traditional color schemes prevented it from becoming a major signal type in the U.S. However, the position-light can still be found in some areas of the former PRR system.

*Color-Position-Light Signals.* Color-position-light signals, which combine facets of color- and position-signal types, were just being developed during this important transitional era of signaling. In the early 1920s, the Baltimore & Ohio introduced a color-position-light signal system that resembled the position-light signal but lacked a central lamp. The new signal utilized two larger green, yellow, and red lenses per row in the vertical, diagonal, and horizontal positions, respectively. In addition, the B&O system added lunar white lights for permissive block signaling. This signal, like

the position-light, could still be read by an engineman with an extinguished light in any given row. White marker lights above and below the colored lights indicated a high or restricted speed route.

In the late 1880s, the electro-pneumatic semaphore signal emerged as the visual symbol of the new and effective automatic block-signal system on the American railroad landscape. In the three decades that followed, as the industry looked to maximize economic return, significant changes to domestic signal systems were implemented that allowed expanded track capacity and efficiency. Beginning in the mid-1910s, new electric light technology facilitated a period of intense growth and development in signal engineering. Railroads rushed to install modern signals that had the unintended side effect of preventing signal aspects and indications from evolving in a uniform manner across the country. As a result, there was no truly standardized American signaling system. Railroads published pocket-sized illustrated guides explaining standard codes and rules for their line, including signal aspects and indications, that enginemen carried to clarify these. By the 1920s, the automatic block system no longer was characterized by the semaphore that had visually defined it in the late 1880s, but by the diversity of the signal system itself.

Sarah Graultry

# CALENDAR

## 2008

**Mar. 15:** 27th Annual Canal Symposium, Easton, PA. Co-sponsored by the National Canal Museum and Lafayette College. Info: <http://canals.org>.

**Apr. 10-12:** Business History Conference, Sacramento, CA. Info: [www.h-net.org/~business/bhcweb](http://www.h-net.org/~business/bhcweb).

**Apr. 28-29:** The 8th Historic Bridge Conference, Columbus, OH. Info: Hojjat Adeli, [adeli.1@osu.edu](mailto:adeli.1@osu.edu).

**May 7-10:** Vernacular Architecture Forum, Annual Meeting, Fresno, CA. Info: [vernaculararchitectureforum.org](http://vernaculararchitectureforum.org).

**May 8-10:** Early American Industries Assn., Annual Meeting, Albany, NY. Info: [www.eaiainfo.org](http://www.eaiainfo.org).

**May 16-19:** Railroad Station Historical Society, Annual Meeting, Charleston, SC. Tours, auction, banquet. Info: Ted Xakellis, 10208 Brunswick Ave., Silver Spring, MD 20902.

**May 18:** Design Histories of Everyday Objects Symposium, Hagley Museum & Library, Wilmington, DE. Info: Carol Lockman, [clockman@hagley.org](mailto:clockman@hagley.org).

**May 19-23:** National Park Service Archeological Prospection Workshop, Fargo, ND. See article in this issue. Info: [www.cr.nps.gov/mwac/](http://www.cr.nps.gov/mwac/).

**May 29-June 1:** SIA 37TH ANNUAL CONFERENCE, SAN JOSE, CA. Sponsored by the Samuel Knight Chapter, SIA. Info: <http://knightsia.org/sia2008>.

**June 16-22:** National Railway Historical Society Convention, Fort Worth, TX. Rail excursions and tours. Info: [www.lonestarrails2008.com](http://www.lonestarrails2008.com).

**Aug. 5-10:** Intl. Committee for the History of Technology Annual Symposium, Victoria, BC. Info: <http://icohtec.uvic.ca/>.

**Sept. 1-4:** First Chinese Intl. Conference on Industrial Heritage, TICCIH 2008, Chengdu, China. See article in this issue. Info: [www.ticcih.org](http://www.ticcih.org).

**Sept. 11-14:** The 6th Preserving the Historic Road Conference, Albuquerque, NM. Info: [www.historicroads.com](http://www.historicroads.com).

**Sept. 11-14:** Society for Commercial Archeology Annual Conference, Albuquerque, NM. Paper sessions and tours of the Old Spanish Trail, Ozark Trail, and Route 66. In conjunction with the Historic Road Conference (see above). Info: [www.sca-roadside.org](http://www.sca-roadside.org).

**Sept. 24-27:** Textile Society of America Symposium, Honolulu, HI. Info: [www.textilesociety.org](http://www.textilesociety.org).

**Sept. 29-Oct. 4:** 16th General Assembly & International Scientific Symposium of the Intl. Council on Monuments & Sites (ICOMOS), Quebec, Canada. Theme: The Spirit of Place between the Intangible and the Tangible. Info: <http://quebec2008.icomos.org>.

**Oct. 9-12:** Society for the History of Technology (SHOT) Annual Meeting, Lisbon, Portugal. Info: [www.shot.jhu.edu](http://www.shot.jhu.edu).

**Nov. 6-7:** Automobility: A Conference on the 100th Anniversary of the Model T, Hagley Museum & Library, Wilmington, DE. See article in this issue. Info: Carol

Department of Social Sciences  
Michigan Technological University  
1400 Townsend Drive  
Houghton MI 49931-1295

**SOCIETY FOR  
INDUSTRIAL  
ARCHEOLOGY**

Address Service Requested

Presorted Standard Mail  
U.S. POSTAGE  
**PAID**  
Permit No. 2431  
Minneapolis, MN